

SECTIONAL DIRECTIONAL CONTROL VALVES



MS 160

B HYDRAULIC PRODUCT

SYSTEM OF FLUID POWER

Sectional Directional Control Valves

MS-160

DIMENSIONS

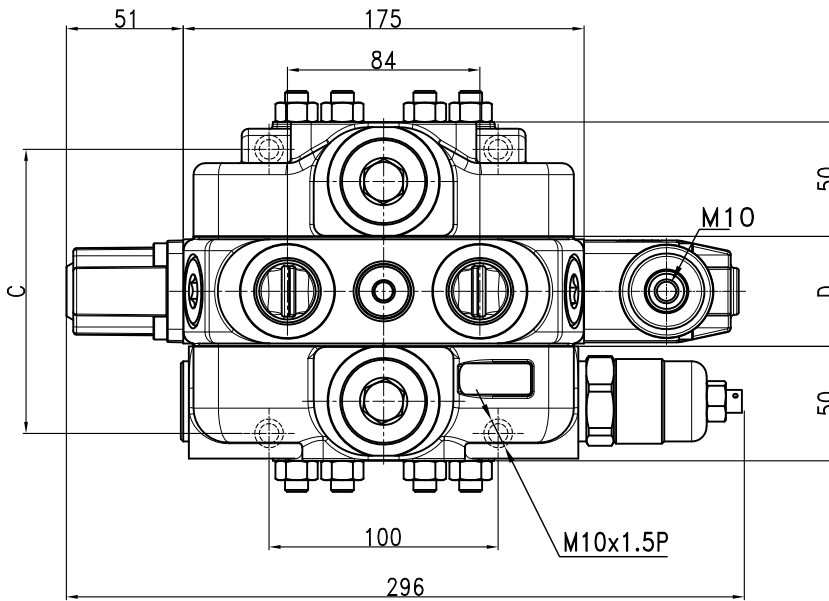

Type	Dimensions	
	C	D
MS-160/1	124	48
MS-160/2	172	96
MS-160/3	220	144
MS-160/4	268	192
MS-160/5	316	240
MS-160/6	364	288
MS-160/7	412	336
MS-160/8	460	384
MS-160/9	508	432
MS-160/10	556	480
MS-100/11	604	528
MS-100/12	652	576

unit : mm

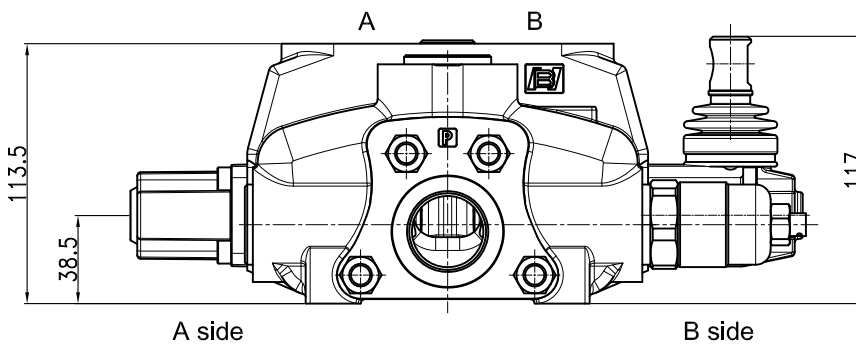

PERFORMANCE

Nominal flow rating : 160 l/min

Operating pressure (Max.) : parallel or tandem circuit : 315 bar
 series circuit : 250 bar

Back pressure (Max.): 25 bar (on outlet port T)

Oil leaks from A (B) to T: 5 c.c/min at 100 bar (1450 psi)

Fluid: best use mineral oil with viscosity ranging between 15 to 75 mm²/s

Fluid temperature : Min. -20°C , Max 80°C ,with NBR (BUNA-N) gaskets

Min. -20°C ,Max 100°C ,with FPM (VITON) seals gaskets

MS-160

RATING DIAGRAM

Open centre
From side inlet to side outlet

Inlet to work port
From side inlet to A port (spool in position 1) or B port (spool in position 2)

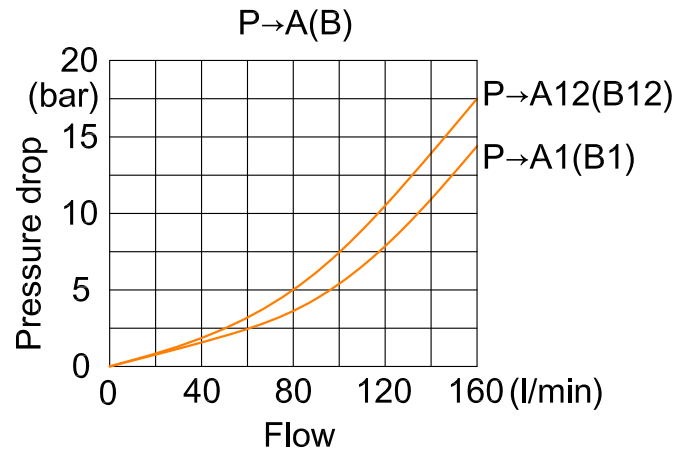
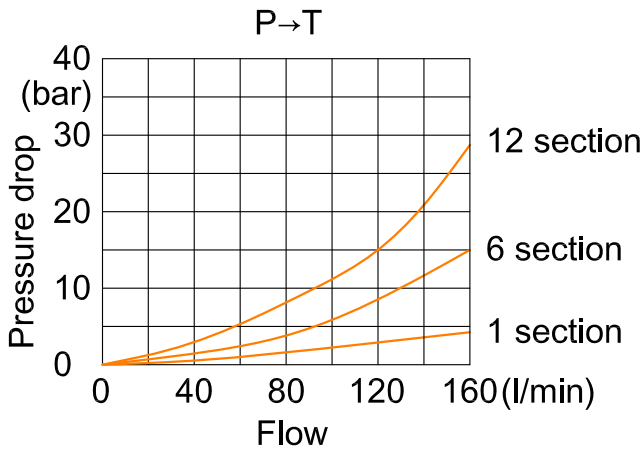

Work port to outlet
From A port (spool in position 2) or B port (spool in position 1) to side outlet

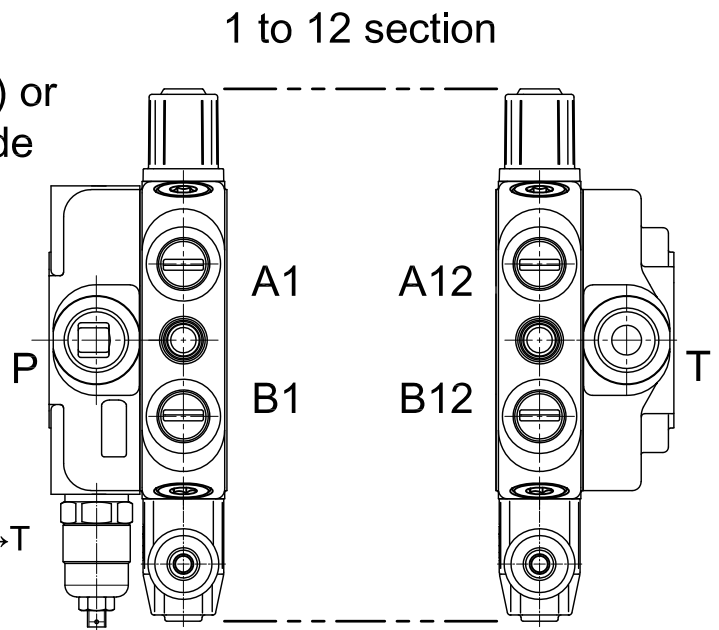
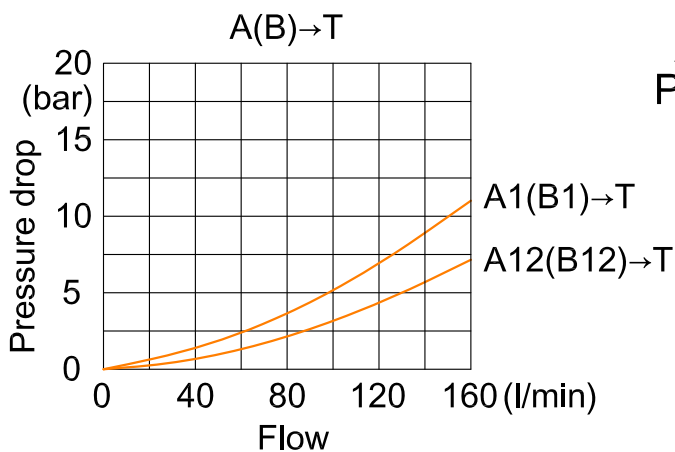



MS-160

ORDERING CODE NUMBER EXAMPLE

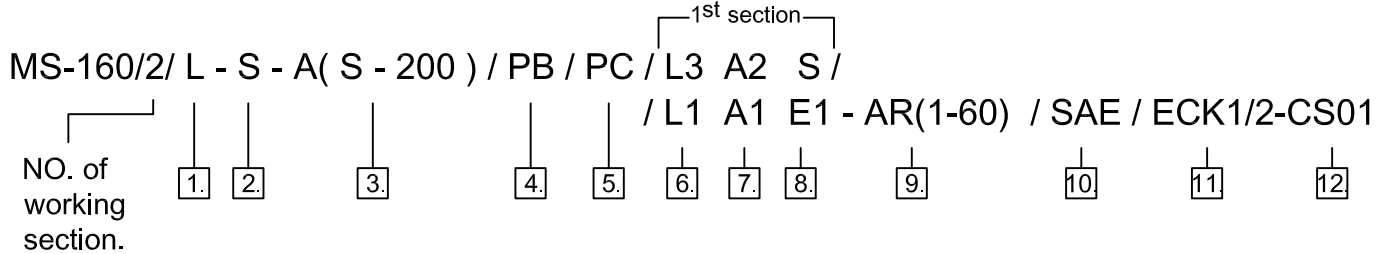

1. Inlet alimentation page.96

Type	Description
L	Left side alimentation
R	Right side alimentation

2. Inlet cover page.97

Type	Description
S	Side inlet.
T	Top inlet.

3. Inlet cover main relief valve page.98

Type	Description
NR	Relief valve blanking plug.
(S-120)	Pilot operated relief valve, range 60 to 315bar/ 870 to 4570 psi. standard setting 120 bar / 1750psi.
(SL-120)	Pilot operated relief valve with capping, range 60 to 315bar/ 870 to 4570 psi. standard setting 120 bar / 1750psi.
(D-80)	Direct-acting relief valve, range 63 to 125bar/ 900 to 1800 psi. standard setting 80 bar / 1150psi.
(DL-80)	Direct-acting relief valve with capping, range 63 to 125bar/ 900 to 1800 psi. standard setting 80 bar / 1150psi.
(D-175)	Direct-acting relief valve, range 100 to 200bar/ 1450 to 2900 psi. standard setting 175 bar / 2500psi.
(DL-175)	Direct-acting relief valve with capping, range 100 to 200bar/ 1450 to 2900 psi. standard setting 175 bar / 2500psi.
(D-250)	Direct-acting relief valve, range 160 to 320bar/ 2300 to 4600 psi. standard setting 250 bar / 3600psi.
(DL-250)	Direct-acting relief valve with capping, range 160 to 320bar/ 2300 to 4600 psi. standard setting 250 bar / 3600psi.

4. Outlet cover page.99

Type	Description
PB	Top outlet with power beyond.
CC	Top outlet with closed center.
SO	Side outlet to tank.
BP	Back pressure option.
TO	Top outlet to tank.

5. Hydraulic circuit page.102

Type	Description
PC	Parallel circuit.
TC	Tandem circuit.

6. "B" side option page.103

Type	Description
L1	Standard lever aluminum pivot box. with neoprene gaiter.
L1A	Standard lever with an extra screw to adjust either side of spool stroke.
L2	Without lever with L2 dust cover.
L3	joystick lever(+axis) with left fulcrum.
L4	Standard lever set as L1A, able to adjust both side of spool stroke.

7. Spool option page.104

Type	Description
A1	Double acting,3 positions with A and B closed in centre.
A2	Double acting,3 positions with A and B open to tank in neutral position.
2A	Double acting,3 positions with A open to tank in neutral position.
2B	Double acting,3 positions with B open to tank in neutral position.
A3	Single acting on A,3 position.B plugged.
A4	Single acting on B,3 position.A plugged.
A5	Double acting,3 positions,with regenerativa in position 1. A shorter stroke is required.
A6	Double acting,3 positions,with regenerativa in position 2. A shorter stroke is required.



MS-160

ORDERING CODE NUMBER EXAMPLE

8."A" side spool positioners page.105

Type	Description
S	Spring return to neutral.
SA	Adjust single side of spool stroke. Spring return to neutral.
P3	On/off pneumatic control. Min. pressure 5 bar(70 psi) Max. pressure 10 bar (140 psi).
D1R	Detent in positions1.Spring return to neutral.
D2R	Detent in positions2.Spring return to neutral.
D12R	Detent in positions 1 or 2.Spring return to neutral.
D3	Detent in three positions.
LH1	External hydraulic pilot to position 1. Spring return to neutral.
LH2	external hydraulic pilot to position 2. Spring return to neutral.
LH3	external hydraulic pilot to position 1 and 2. Spring return to neutral.
E1	On/off electro-hydraulic control with extrnal pilot and solenoid function to position 1.Spring return to neutral.
E2	On/off electro-hydraulic control with extrnal pilot and solenoid function to position 2.Spring return to neutral.
E3	On/off electro-hydraulic control with extrnal pilot and solenoid function to position 1 and 2.Spring return to neutral.
EP1	On/off electro-pneumatic control with extrnal pilot and solenoid function to position 1. Spring return to neutral.
EP2	On/off electro-pneumatic control with extrnal pilot and solenoid function to position 2. Spring return to neutral.
EP3	On/off electro-pneumatic control with extrnal pilot and solenoid function to position 1 and 2. Spring return to neutral.
PP	Proportional hydraulic control.

9.Port Relief valves page.108

Type	Description
A	Mounted on port A.
B	Mounted on port B.
C	Mounted on port A and B.
Relief valve	
R(1-60)	Range 50 to 120 bar/ 725 to 1750 psi. standard setting 63 bar / 900psi.
R(2-100)	Range 100 to 250 bar/ 1450 to 3600 psi. standard setting 100 bar / 1450psi.
R(3-200)	Range 160 to 315 bar/ 2300 to 4600 psi. standard setting 200 bar / 2900psi.

Type	Description
Anti-shock valve	
RC(1-50)	Range 35 to 90 bar/ 510 to 1300 psi. standard setting 60 bar / 870psi.
RC(2-100)	Range 90 to 250 bar/ 1300 to 3600 psi. standard setting 120 bar / 1800psi.
RC(3-200)	Range 180 to 350 bar/ 2600 to 5100 psi. standard setting 200 bar / 2900psi.
Anti-cavitation valve	
C	Anti-cavitation

10.Port threads option page.115

Type	Description
BSP	G.
SAE	UN-UNF.

11.EL control pilot kit page. 110

Type	Description
ECK1/1-12	Compele kit with pressure reducing valve, manifold and pipes. (1-12 sections)
ECK2/1-12	Manifold kit and pressure reducing valve for connection to the main circuit.(1-12 sections)

12.Coil series page. 111

Type	Description
CS01	Connection:A EN 175301-803 ISO 4400 (DIN.43650) Voltage : 12-24VDC
CS02	Connection:lead wires connection Voltage : 12-24VDC
CS03	Connection:AMP Junior connection Voltage : 12-24VDC
CS04	Connection:M27x1 connection Voltage : 12-24VDC
EP	Connection:lead wires connection Voltage : 12-24VDC ("A" side has to be used with EP)

MS-160

1. Inlet alimentation

Left inlet

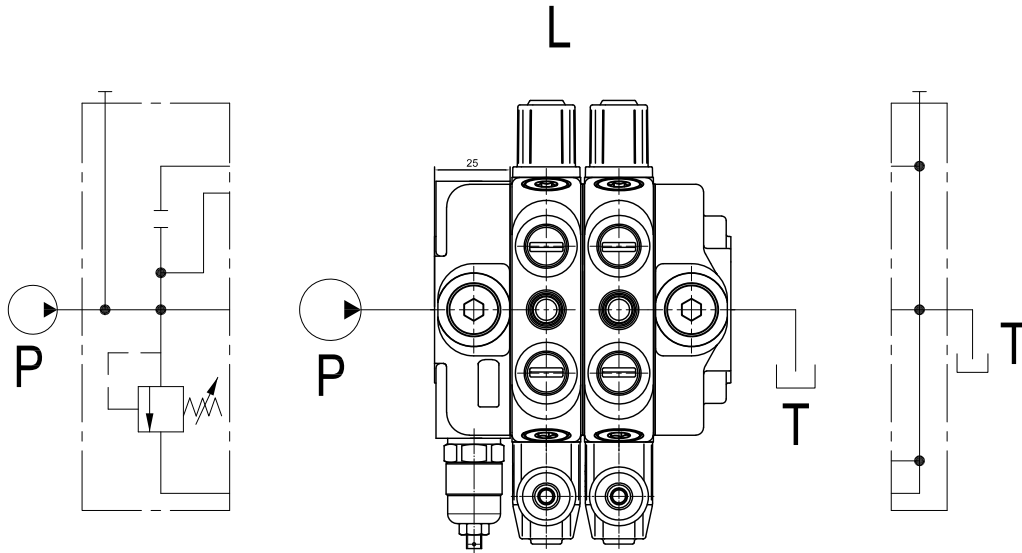

Right inlet

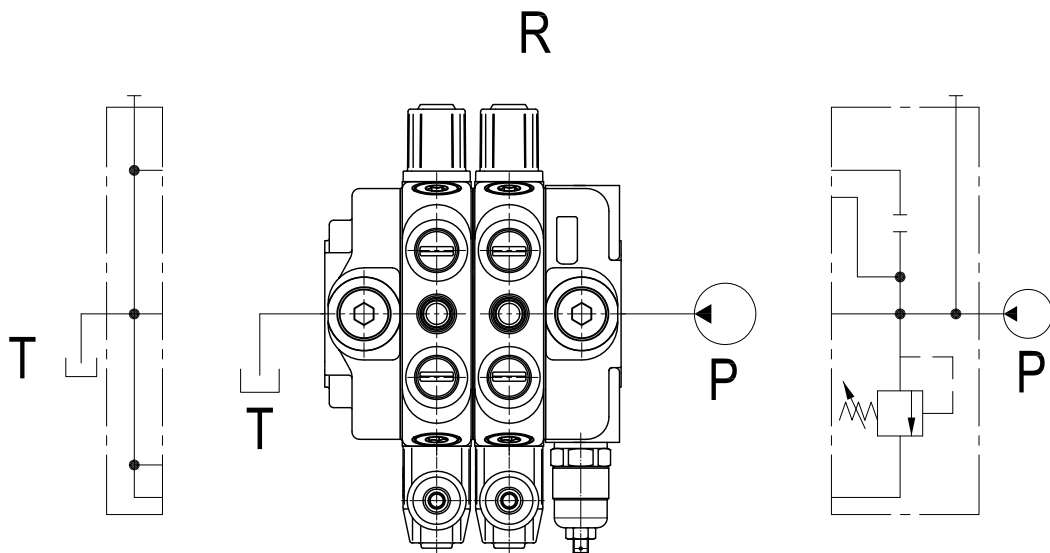

MS-160

2. Inlet cover

Inlet cover and position

Side inlet.

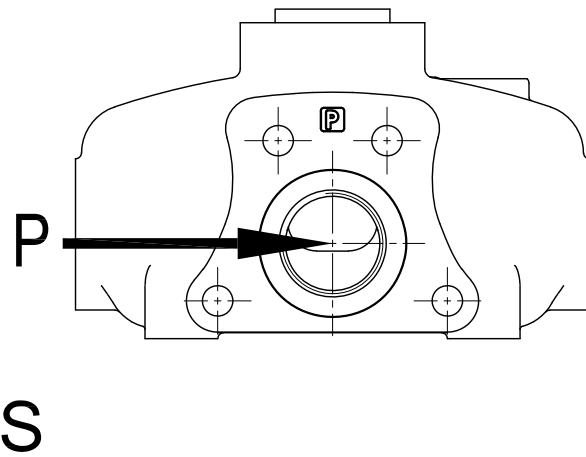
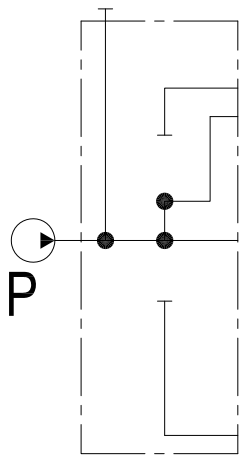

Top inlet.

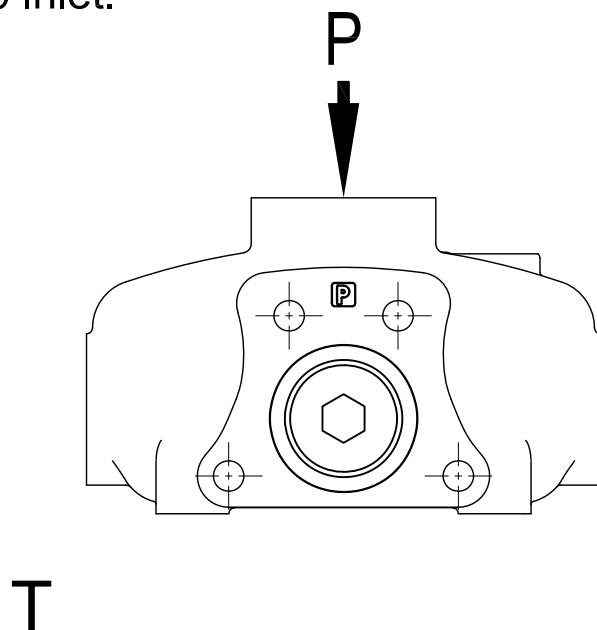
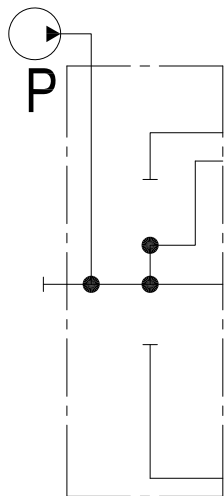

MS-160

3. Inlet cover main relief valve

Main relief valve position

A (D - 175)

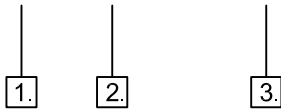

1. NR=None relief valve.
A=Mounted on port A.
B=Mounted on port B.
2. Main relief type(S, D)
Optional: with capping (SL, DL)
3. S / SL(120) : Standard pressure setting
in 60 - 315bar.
Standard pressure 120bar/1750psi
D / DL(80) : Standard pressure setting
in 63 - 125bar.
Standard pressure 80bar/1150psi
D / DL(175) : Standard pressure setting
in 100 - 200bar.
Standard pressure 175bar/2500psi
D / DL(250) : Standard pressure setting
in 160 - 320bar.
Standard pressure 250bar/3600psi

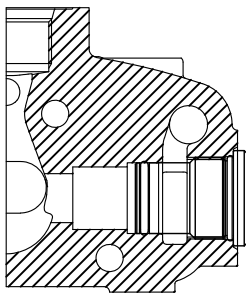

NR : Relief valve blanking plug

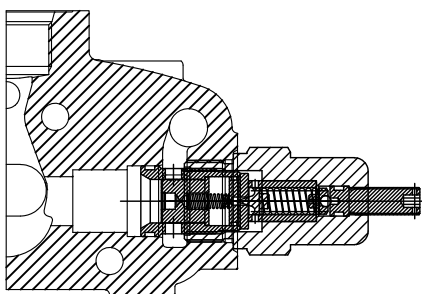

S : Pilot operated relief valve

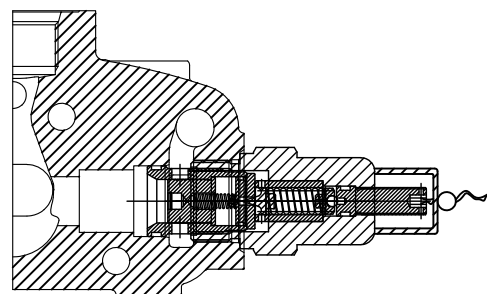

SL : Pilot operated relief valve
with capping

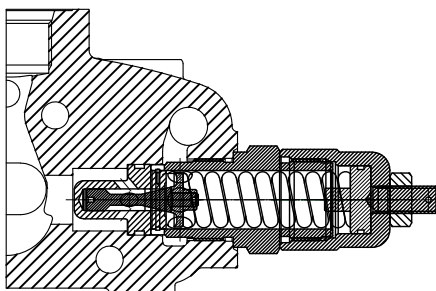

D : Direct-acting relief valve

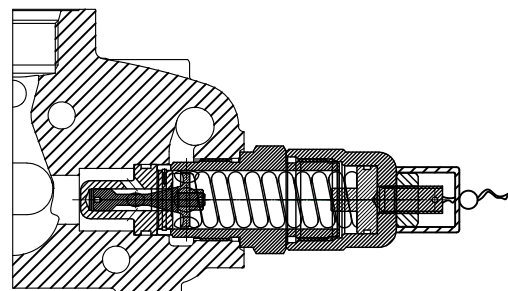

DL : Direct-acting relief valve
with capping

MS-160

4. Outlet cover

Outlet cover and position

Top outlet with power beyond

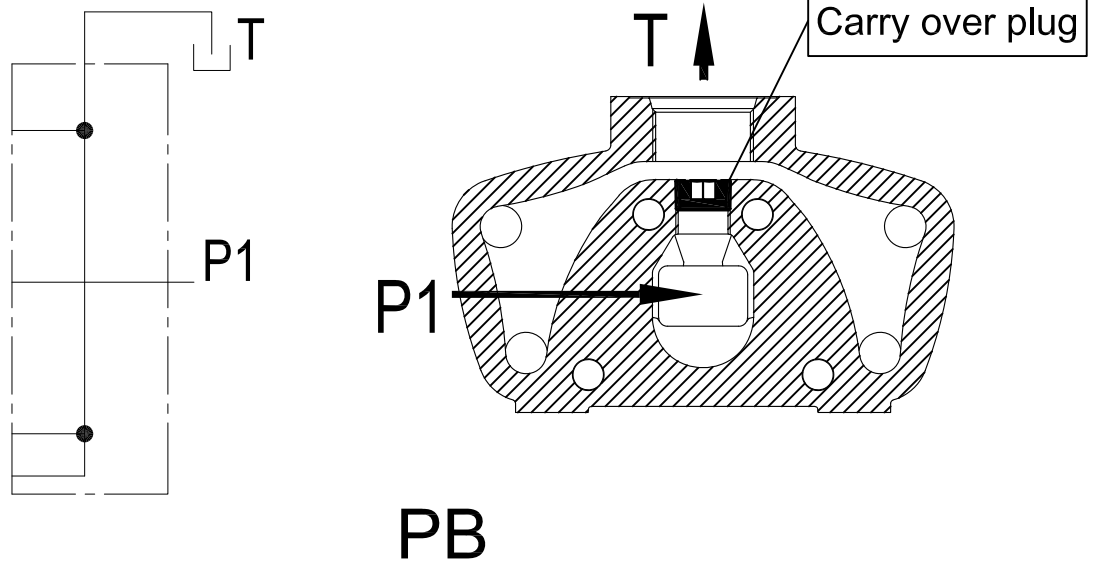

Top outlet with closed center

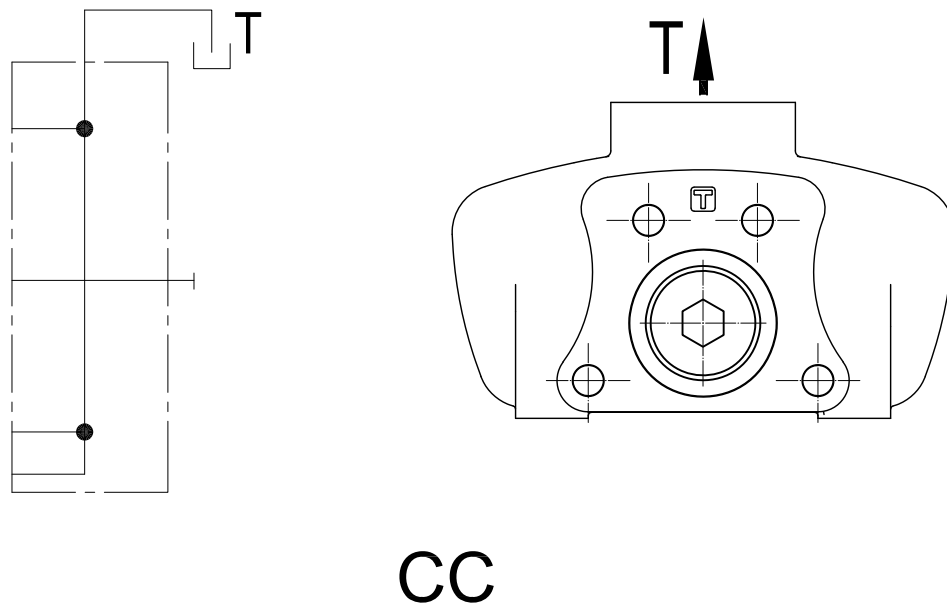

MS-160

4. Outlet cover

Outlet cover and position

Side outlet to tank

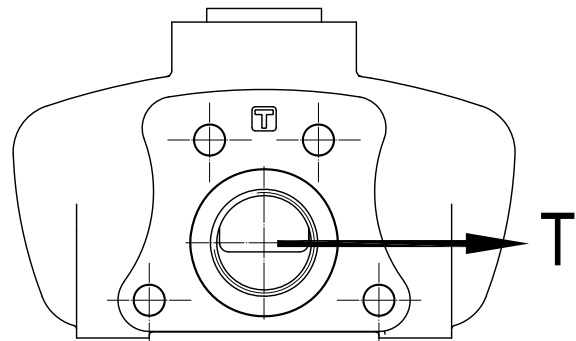
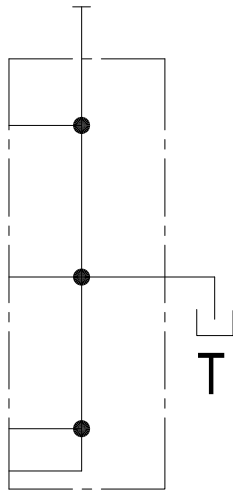

SO

Top outlet to tank

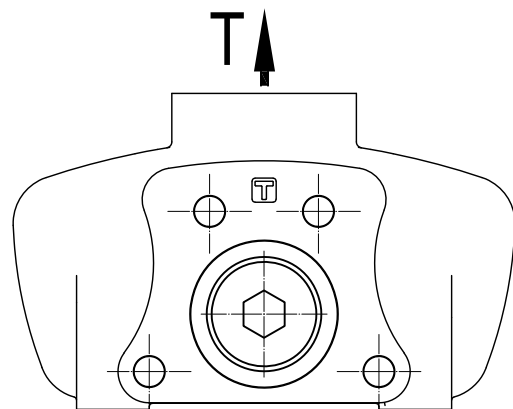
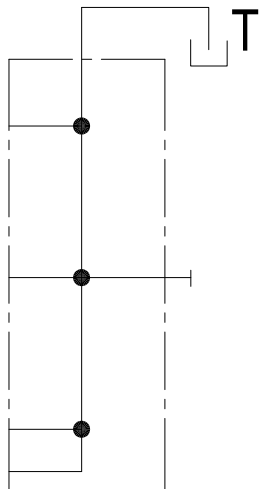

TO

MS-160

4. Outlet cover

Outlet cover and position

Back pressure option
(For use with electro-hydraulic control)

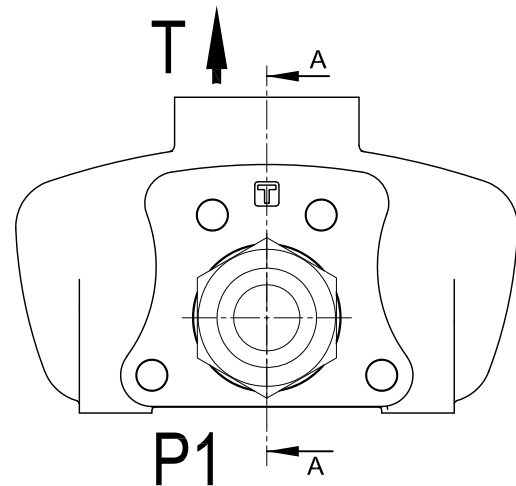
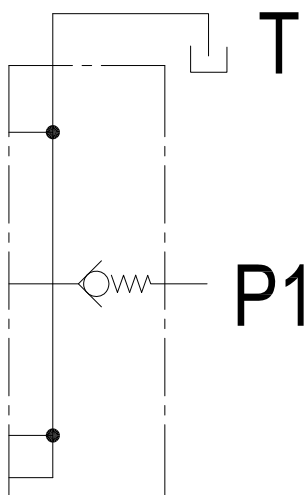

BP

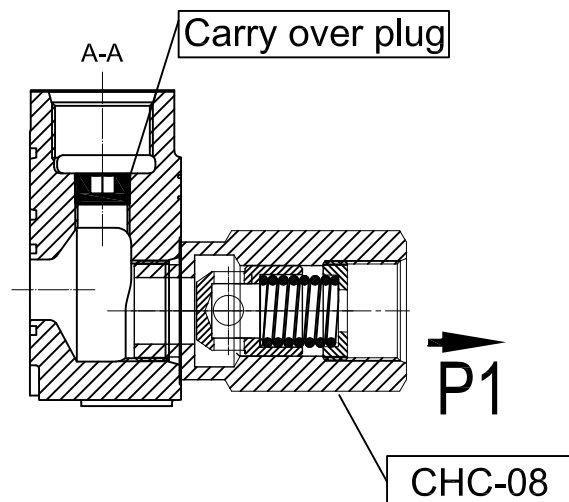

Carry-over with CHC-08 back pressure valve set at 10bar(145 psi) on the free line(side outlet).Used for electro-hydraulic controls.

MS-160

5. Hydraulic circuit

Parallel circuit

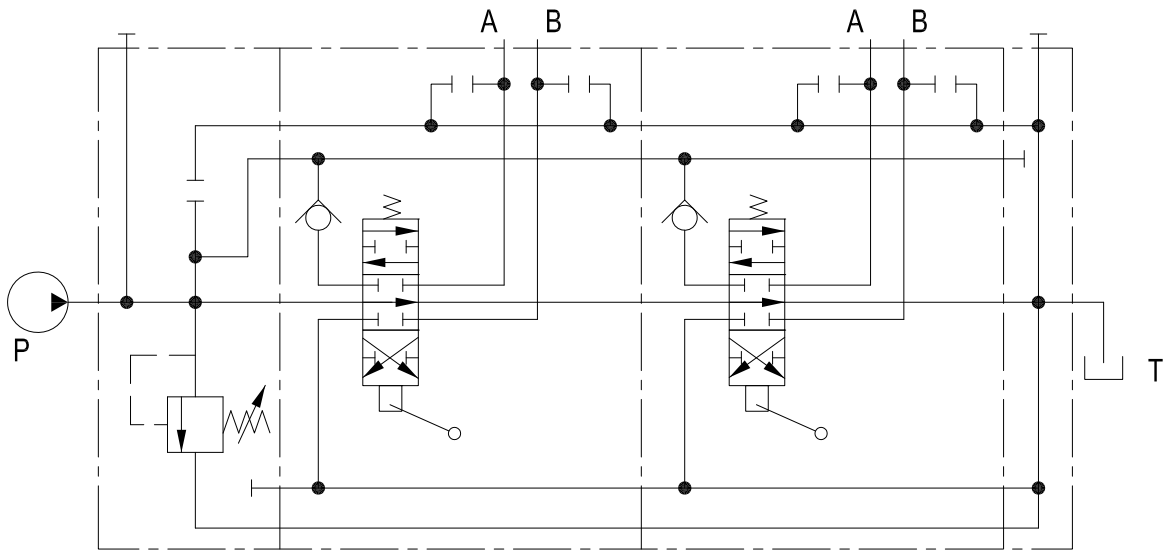

PC

Tandem circuit

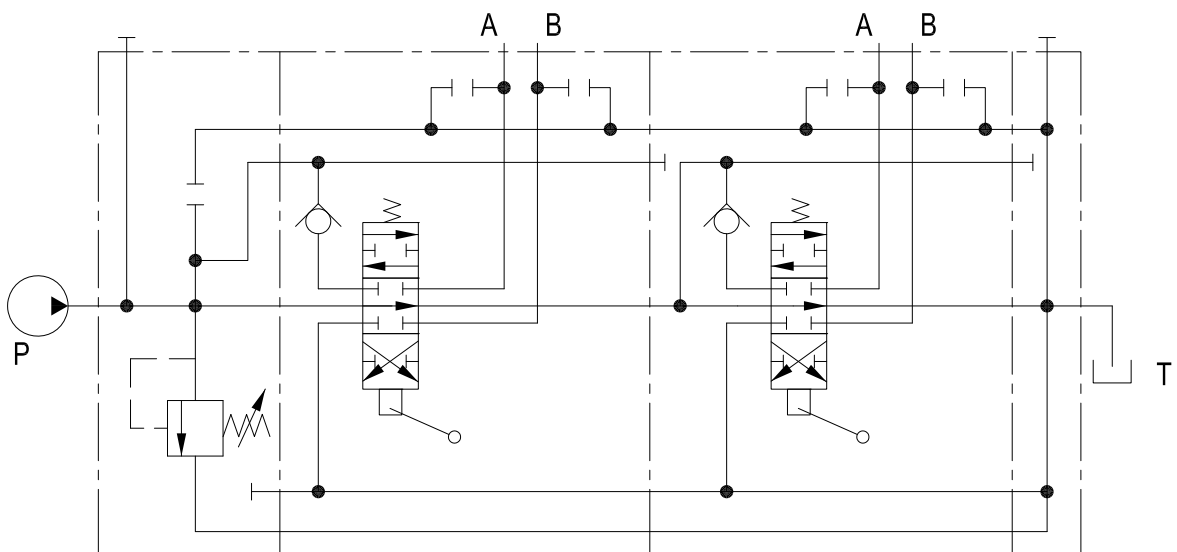

TC

MS-160

6. "B" side option

Spool control B port side

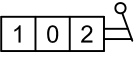
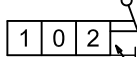
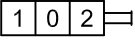
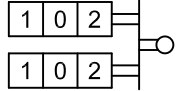
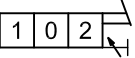
Type	Scheme	Description	Type	Scheme	Description
L1		Standard lever aluminum pivot box with neoprene gaiter.	L1A		Standard lever with an extra screw to adjust either side of spool stroke
L2		Without lever with L2 dust cover.	L3		"L3 of 4 Type" joystick lever(+ axis) with left fulcrum.
L4		Standard lever set as L1A, able to adjust both side of spool stroke			

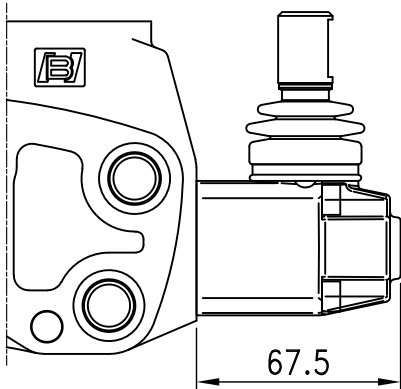

L1

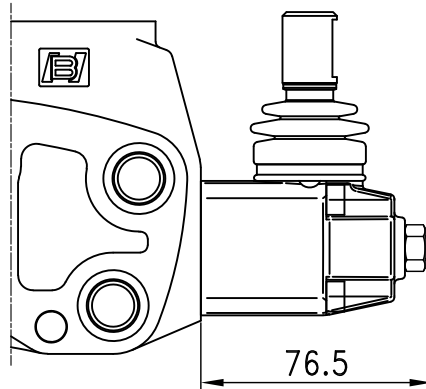

L1A

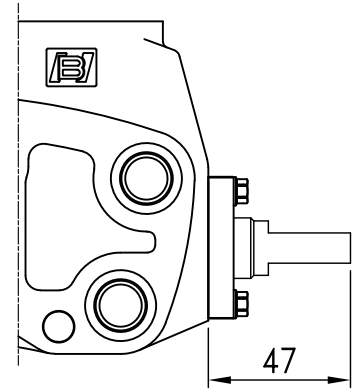

L2

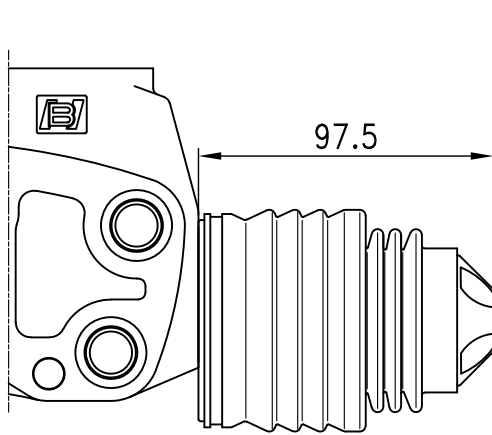

L3 ←
B side

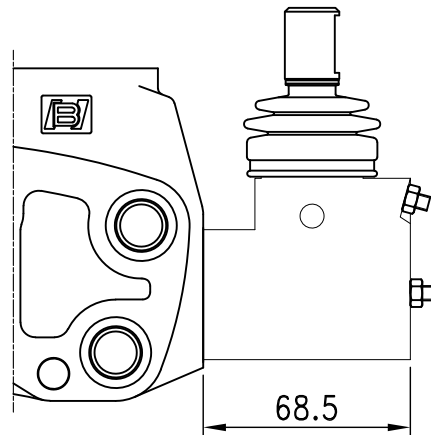

L4

MS-160

L3-1

View from B side

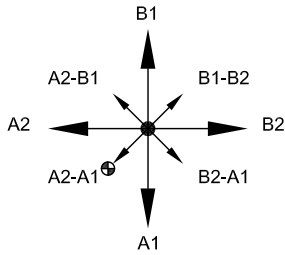

Bottom fulcrum

L3-3*

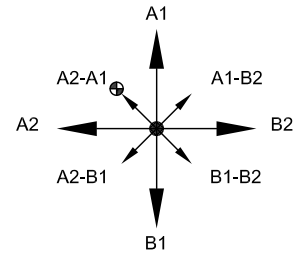

Top fulcrum

L3-2

View from B side

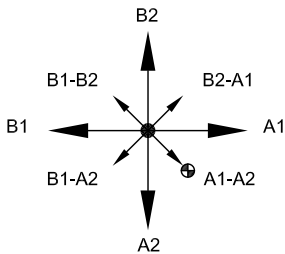

Bottom fulcrum

L3-4*

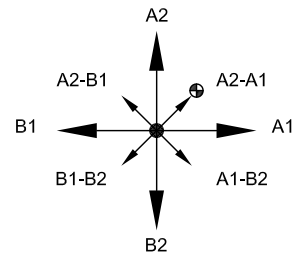

Top fulcrum

Note: * Configurations not available with service port valve.

7. Spool option

Spool

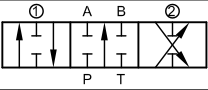
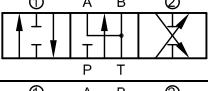
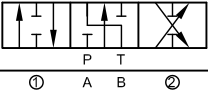
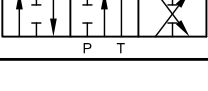
Type	Scheme
A1	
A2	
2A	
2B	

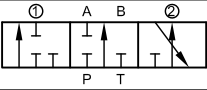
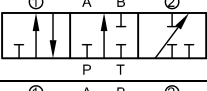
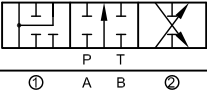
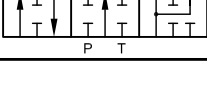
Type	Scheme
A3	
A4	
A5	
A6	

MS-160

8. "A" side spool positioners

Spool control A port side

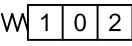
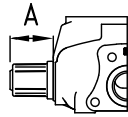
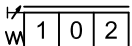
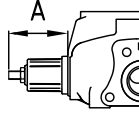
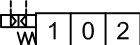
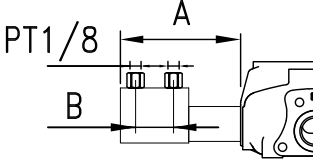
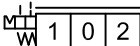
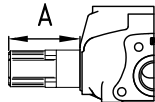
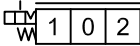
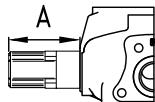
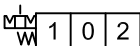
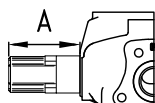
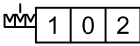
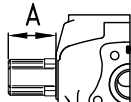
Type	Scheme	Description	Dimensions
S		S = Spring centered.	 51 (2.01)
SA		SA = Spring return to neutral. Adjust single side of spool stroke.	 66 (2.59)
P3		P = On/off pneumatic control Min. pressure 5 bar (70 psi) Max. pressure 10 bar (140 psi)	 A 130 (5.12) B 58 (2.28)
D1R		D1R = Detent in positions1. Spring return to neutral.	 82.5 (3.24)
D2R		D2R = Detent in position2. Spring return to neutral.	 82.5 (3.24)
D12R		D12R = Detent in positions1 or 2. Spring return to neutral.	 82.5 (3.24)
D3		D3 = Detent in three positions	 51 (2.01)

MS-160

8. "A" side spool positioners

Spool control A port side

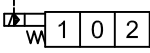
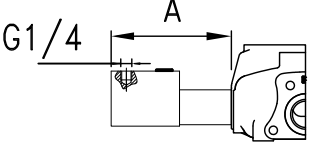
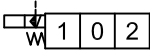
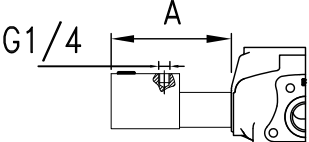
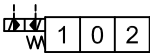
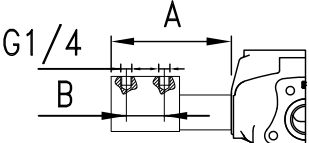
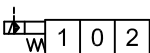
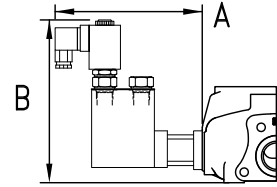
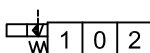
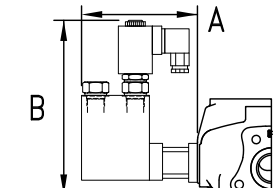
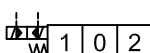
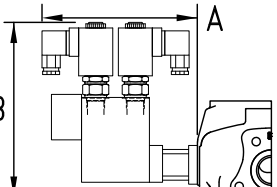
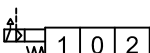
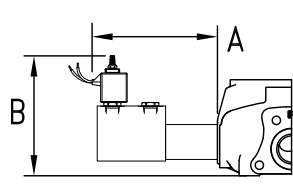
Type	Scheme	Description	Dimensions	
LH1		LH1 = External hydraulic pilot to position 1. Spring return to neutral.		130 (5.12)
LH2		LH2 = External hydraulic pilot to position 2. Spring return to neutral.		130 (5.12)
LH3		LH3 = External hydraulic pilot to position 1 and 2. Spring return to neutral.		A 130 (5.12) B 58 (2.28)
E1		E1=On/off electro-hydraulic control with extrnal pilot and solenoid function to position 1. Spring return to neutral. Voltage:12VDC,24VDC		A 165 (6.49) B 180 (7.08)
E2		E2=On/off electro-hydraulic control with extrnal pilot and solenoid function to position 2. Spring return to neutral. Voltage:12VDC,24VDC		A 145 (5.71) B 180 (7.08)
E3		E3=On/off electro-hydraulic control with extrnal pilot and solenoid function to position 1 and 2. Spring return to neutral. Voltage:12VDC,24VDC		A 165 (6.49) B 180 (7.08)
EP1		EP1=On/off electro-pneumatic control with extrnal pilot and solenoid function to position 1. Spring centered. Voltage:12VDC,24VDC		A 140 (5.51) B 110 (4.33)

MS-160

8. "A" side spool positioners

Spool control A port side

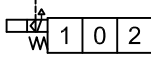
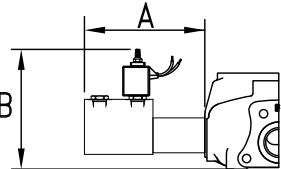
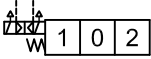
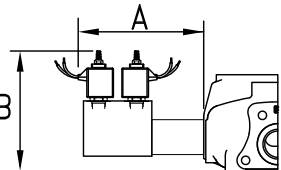
Type	Scheme	Description	Dimensions	
EP2		EP2=On/off electro-pneumatic control with external pilot and solenoid function to position 2. Spring centered. Voltage:12VDC,24VDC		A 130 (5.12) B 110 (4.33)
EP3		EP3=On/off electro-pneumatic control with external pilot and solenoid function to position 1 and 2. Spring centered. Voltage:12VDC,24VDC		A 140 (5.51) B 110 (4.33)

Spool control A and B-port side

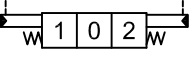
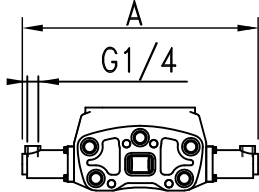
PP		PP = Proportional hydraulic control.		313 (12.32)
----	---	--------------------------------------	--	----------------

MS-160

9.Port Relief valves

With Port Valve Prearrangement

L1 A2 S - NA

1. NA= No relieve valve (can be omitted)

1.

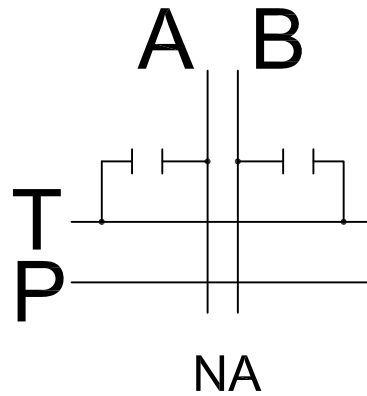
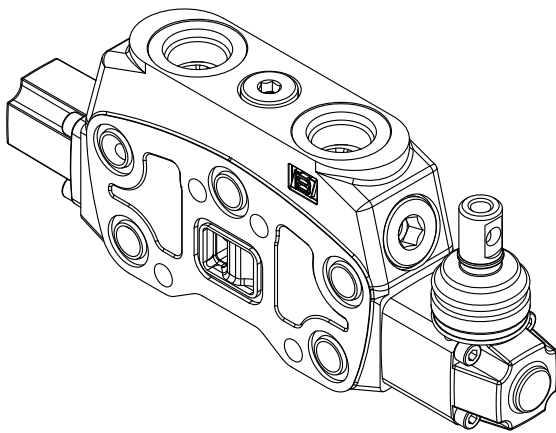

Anti-shock Valves

A R (2 - 100)

1. 2. 3. 4.

- 1. A= On A side
B= On B side
C= On both sides
- 2. Valve options
- 3. Spring options
- 4. Pressure setting

Spring type	01	02	03
Max. Pressure	120	250	315
Min. Pressure	50	100	160

unit : bar

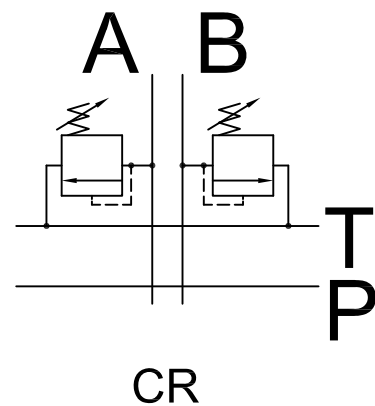
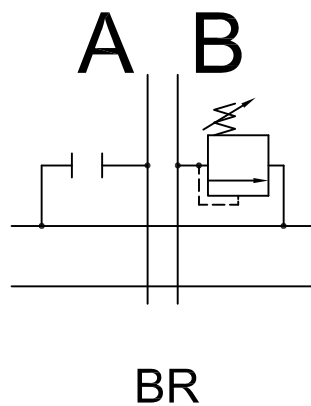
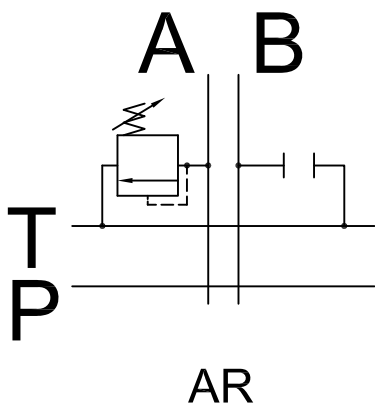

MS-160

9.Port Relief valves

Anti-shock and Anti-cavitation Valves

Spring type	01	02	03
Max. Pressure	90	250	350
Min. Pressure	35	100	180

unit : bar

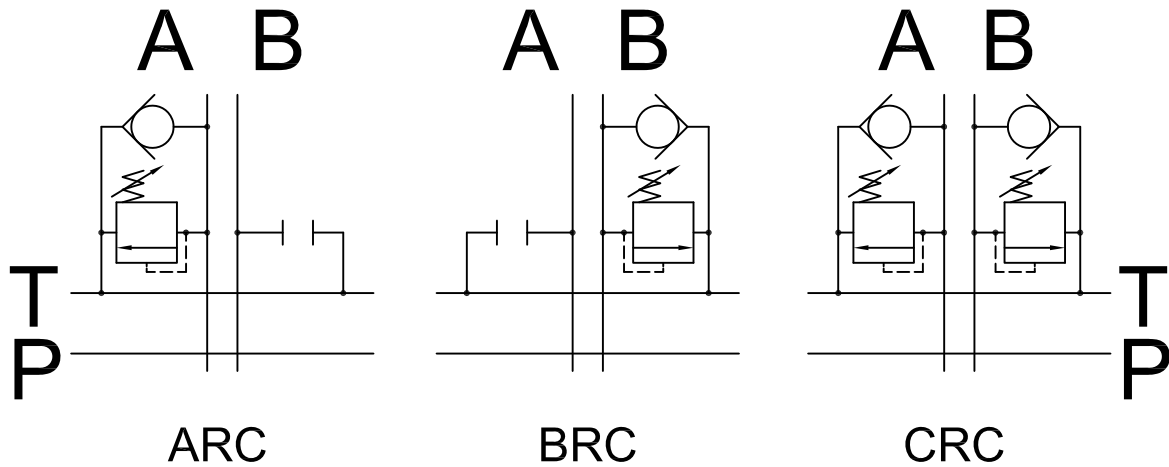

Anti-cavitation Valves

L1 A2 S - A C

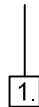

1. A=On A side
B=On B side
C=On both sides

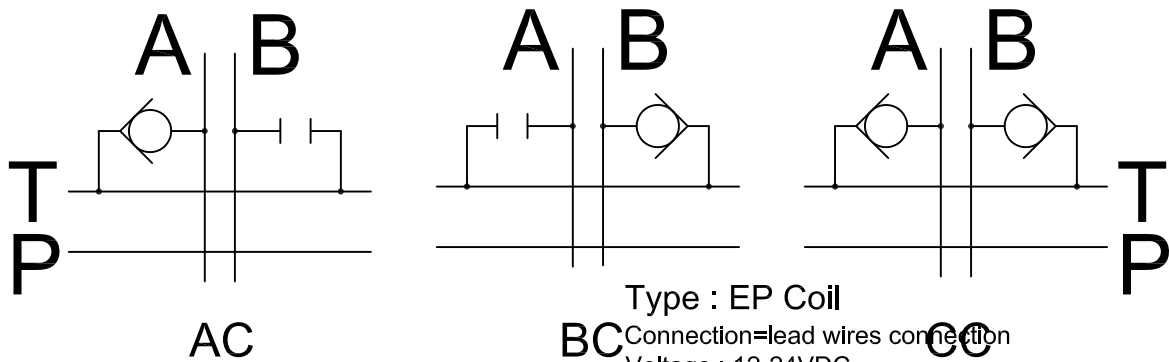

Type : EP Coil
Connection=lead wires connection
Voltage : 12-24VDC

MS-160

10.EL control pilot kit

EL control pilot kit

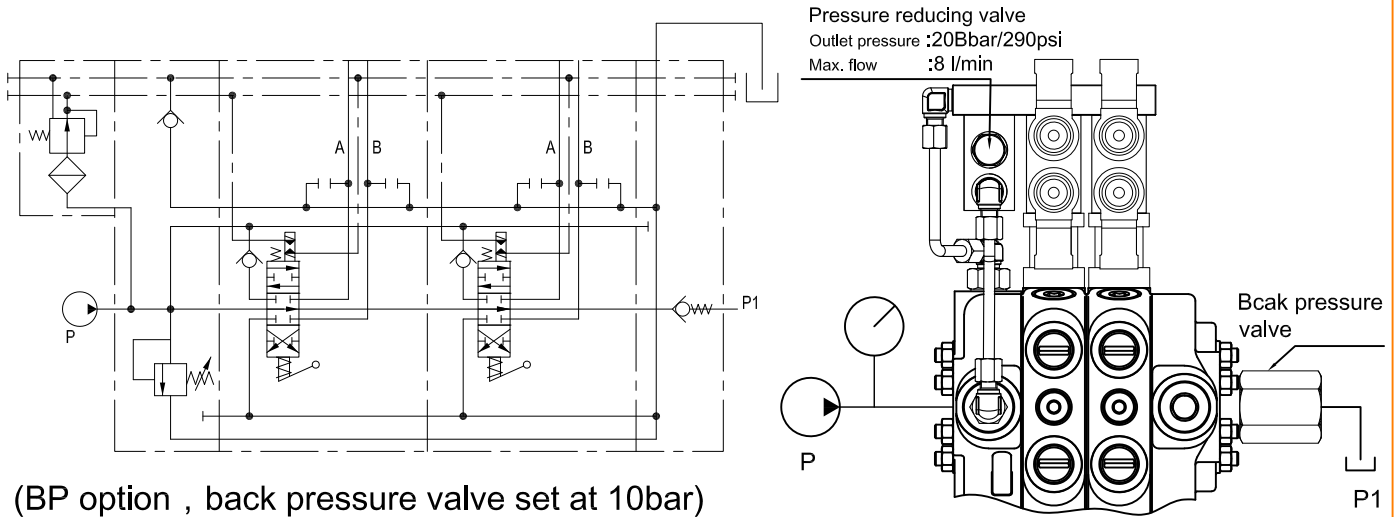

Compele kit with pressure reducing valve, manifold and pipes.

ECK1/1-12

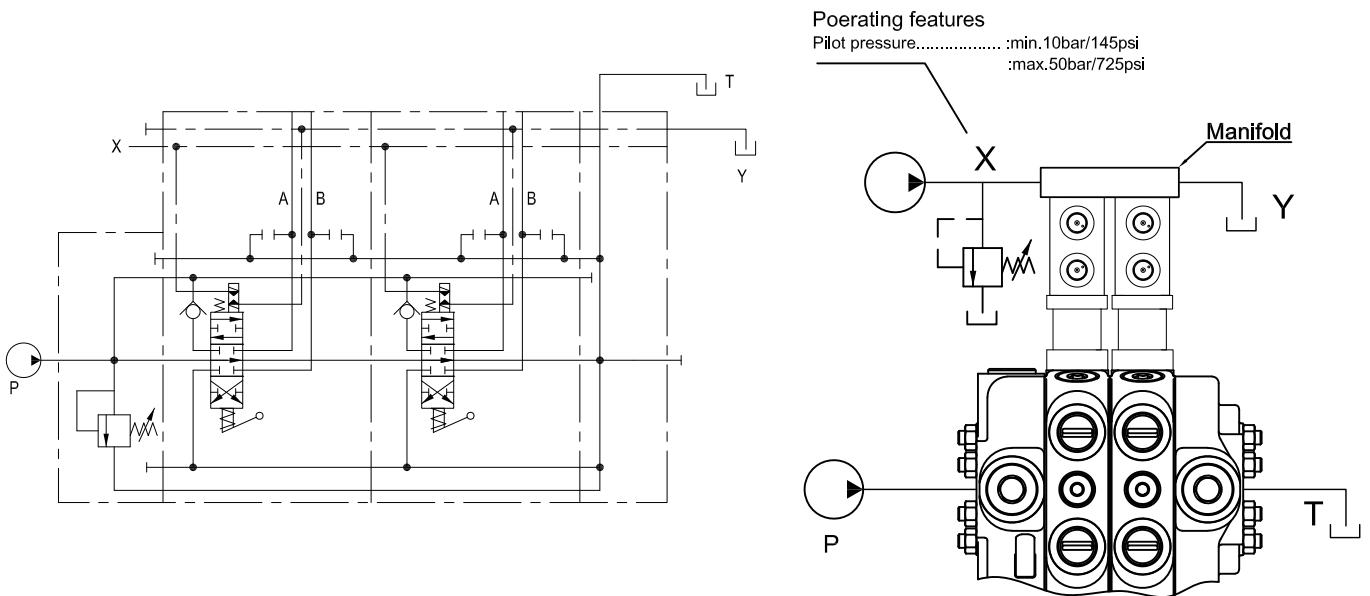

Manifold kit and pressure reducing valve for connection to the main circuit.

ECK2/1-12

MS-160

11. Coil Series

Coil series option

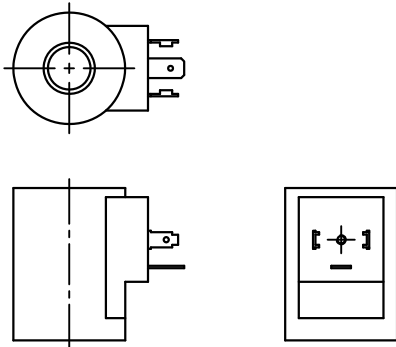

Type : CS01
 Connection=A EN 175301-803 ISO 4400(DIN.43650)
 Voltage : 12-24VDC

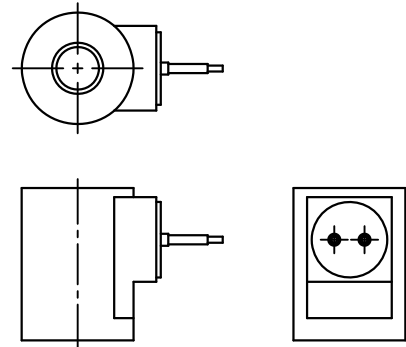

Type : CS02
 Connection=lead wires connection
 Voltage : 12-24VDC

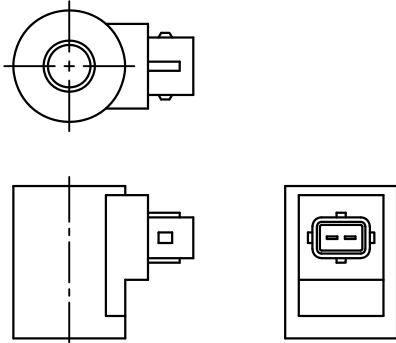

Type : CS03
 Connection=AMP Junior connection
 Voltage : 12-24VDC

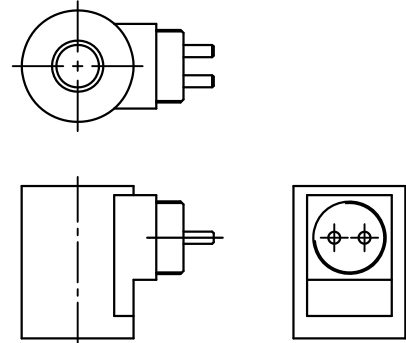

Type : CS04
 Connection=M27x1 connection
 Voltage : 12-24VDC

DIMENSIONS

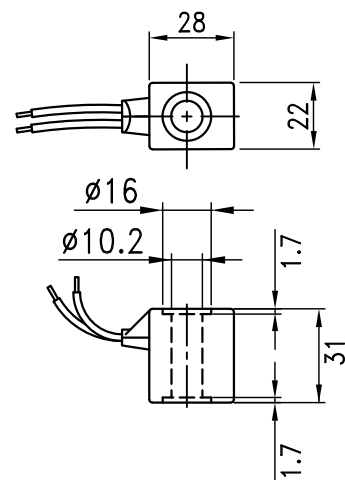
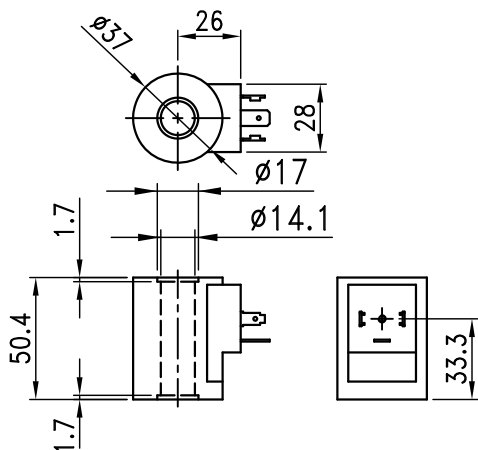

MS-160-Working section

ORDERING CODE NUMBER EXAMPLE

WS-MS-160/ 1. 2. - 3. - 4. - 5. - 6. - 7.

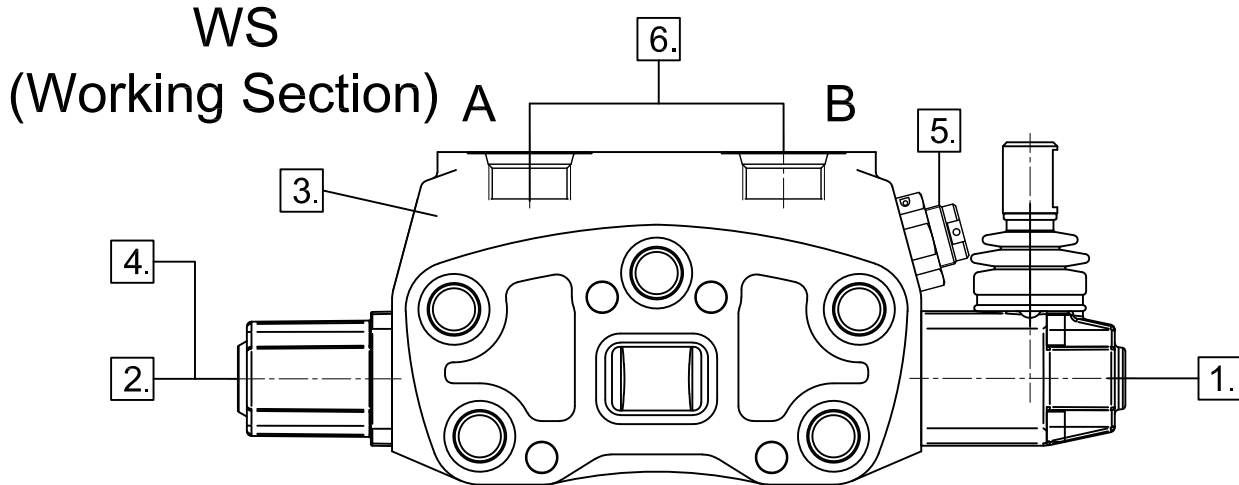

1."B" side option page.103

Type	Description
L1	Standard lever aluminum pivot box. with neoprene gasket.
L1A	Standard lever with an extra screw to adjust either side of spool stroke.
L2	Without lever with L2 dust cover.
L3	joystick lever(+axis) with left fulcrum.
L4	Standard lever set as L1A, able to adjust both side of spool stroke.

2.Spool option page.104

Type	Description
A1	Double acting,3 positions with A and B closed in centre.
A2	Double acting,3 positions with A and B open to tank in neutral position.
2A	Double acting,3 positions with A open to tank in neutral position.
2B	Double acting,3 positions with B open to tank in neutral position.
A3	Single acting on A,3 position.B plugged.
A4	Single acting on B,3 position.A plugged.
A5	Double acting,3 positions,with regenerativa in position 1. A shorter stroke is required.
A6	Double acting,3 positions,with regenerativa in position 2. A shorter stroke is required.

3.Hydraulic circuit page.102

Type	Description
PC	Parallel circuit.
TC	Tandem circuit.

4."A" side spool positioners page.105

Type	Description
S	Spring return to neutral.
SA	Adjust single side of spool stroke. Spring return to neutral.
P3	On/off pneumatic control. Min. pressure 5 bar(70 psi) Max. pressure 10 bar (140 psi).
D1R	Detent in positions1.Spring return to neutral.
D2R	Detent in positions2.Spring return to neutral.
D12R	Detent in positions 1 or 2.Spring return to neutral.
D3	Detent in three positions.
LH1	External hydraulic pilot to position 1. Spring return to neutral.
LH2	external hydraulic pilot to position 2. Spring return to neutral.
LH3	external hydraulic pilot to position 1 and 2. Spring return to neutral.
E1	On/off electro-hydraulic control with extrnal pilot and solenoid function to position 1.Spring return to neutral.
E2	On/off electro-hydraulic control with extrnal pilot and solenoid function to position 2.Spring return to neutral.



MS-160-Working section

ORDERING CODE NUMBER EXAMPLE

4."A" side spool positioners page.105

Type	Description
E3	On/off electro-hydraulic control with extrnal pilot and solenoid function to position 1 and 2.Spring return to neutral.
EP1	On/off electro-pneumatic control with extrnal pilot and solenoid function to position 1. Spring return to neutral.
EP2	On/off electro-pneumatic control with extrnal pilot and solenoid function to position 2. Spring return to neutral.
EP3	On/off electro-pneumatic control with extrnal pilot and solenoid function to position 1 and 2. Spring return to neutral.
PP	Proportional hydraulic control.

5.Port Relief valves page.108

Type	Description
NA	No relief valve.
A	Mounted on port A.
B	Mounted on port B.
C	Mounted on port A and B.
Relief valve	
R(1-60)	Range 50 to 120 bar/ 725 to 1750 psi. standard setting 63 bar / 900psi.
R(2-100)	Range 100 to 250 bar/ 1450 to 3600 psi. standard setting 100 bar / 1450psi.
R(3-200)	Range 160 to 315 bar/ 2300 to 4600 psi. standard setting 200 bar / 2900psi.
Anti-shock valve	
RC(1-50)	Range 35 to 90 bar/ 510 to 1300 psi. standard setting 60 bar / 870psi.
RC(2-100)	Range 90 to 250 bar/ 1300 to 3600 psi. standard setting 120 bar / 1800psi.
RC(3-200)	Range 180 to 350 bar/ 2600 to 5100 psi. standard setting 200 bar / 2900psi.
Anti-cavitation valve	
C	Anti-cavitation

6.Port threads option page.115

Type	Description
BSP	G.
SAE	UN-UNF.

7.Coil series page.111

Type	Description
CS01	Connection:A EN 175301-803 ISO 4400 (DIN.43650) Voltage : 12-24VDC
CS02	Connection:lead wires connection Voltage : 12-24VDC
CS03	Connection:AMP Junior connection Voltage : 12-24VDC
CS04	Connection:M27x1 connection Voltage : 12-24VDC
EP	Connection:lead wires connection Voltage : 12-24VDC ("A" side has to be used with EP)

MS-160-Inlet cover

ORDERING CODE NUMBER EXAMPLE

IC-MS-160/ L - S - A (D - 175) - BSP

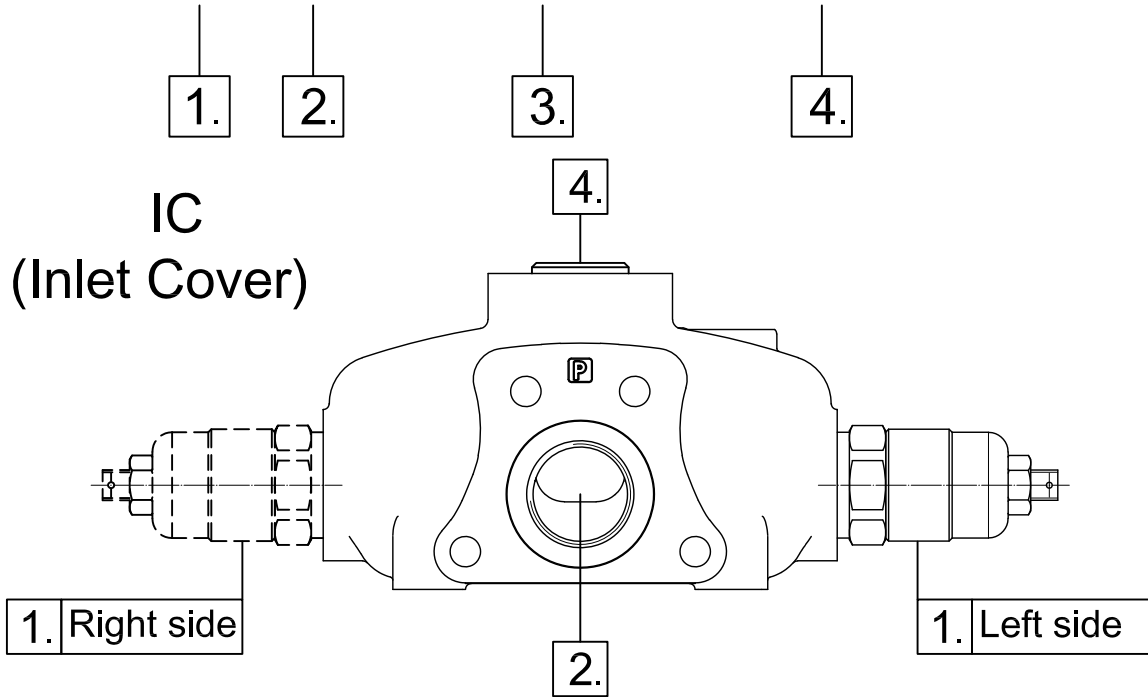

1. Inlet Alimentation page.96

Type	Description
L	Left side Alimentation
R	Right side Alimentation

2. Inlet cover page.97

Type	Description
S	Side inlet.
T	Top inlet.

3. Inlet cover relief valve page.98

Type	Description
NR	Relief valve blanking plug.
(S-120)	Pilot operated relief valve, range 60 to 315bar/ 870 to 4570 psi. standard setting 120 bar / 1750psi.
(SL-120)	Pilot operated relief valve with capping, range 60 to 315bar/ 870 to 4570 psi. standard setting 120 bar / 1750psi.
(D-80)	Direct-acting relief valve, range 60 to 125bar/ 900 to 1800 psi. standard setting 80 bar / 1150psi.
(DL-80)	Direct-acting relief valve with capping, range 60 to 125bar/ 900 to 1800 psi. standard setting 80 bar / 1150psi.

3. Inlet cover relief valve page.98

Type	Description
(D-175)	Direct-acting relief valve, range 100 to 200bar/ 1450 to 2900 psi. standard setting 175 bar / 2500psi.
(DL-175)	Direct-acting relief valve with capping, range 100 to 200bar/ 1450 to 2900 psi. standard setting 175 bar / 2500psi.
(D-250)	Direct-acting relief valve, range 160 to 320bar/ 2300 to 4600 psi. standard setting 250 bar / 3600psi.
(DL-250)	Direct-acting relief valve with capping, range 160 to 320bar/ 2300 to 4600 psi. standard setting 250 bar / 3600psi.

4. Port threads option page.115

Type	Description
BSP	G.
SAE	UN-UNF.

MS-160-Outlet cover

ORDERING CODE NUMBER EXAMPLE

OC-MS-160/ PB - BSP

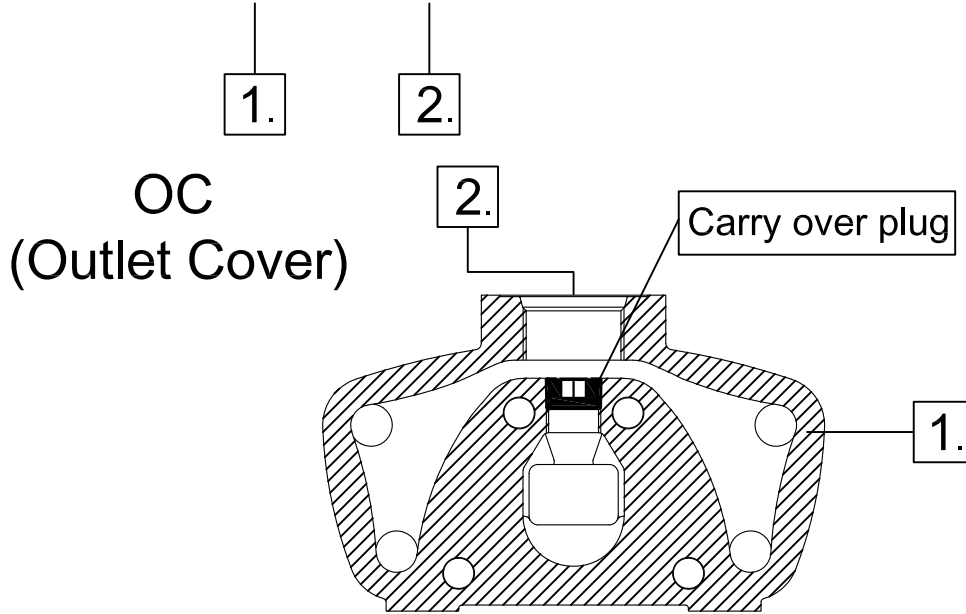

1.Outlet cover		page.99	2.Port threads option		page.115
Type	Description		Type	Description	
PB	Top outlet with power beyond.		BSP	G.	
CC	Top outlet with closed center.		SAE	UN-UNF.	
SO	Side outlet to tank.				
BP	Back pressure option.				
TO	Top outlet to tank.				

12.Port threads option

Port threads

PORT	BSP	SAE
P	G3/4	1 5/16-12UN
A and B port	G3/4	1 1/16-12UN
T	G1	1 5/16-12UN