

SECTIONAL DIRECTIONAL CONTROL VALVE



Ms 060

B HYDRAULIC PRODUCT

SYSTEM OF FLUID POWER

Sectional Directional Control Valves

MS-060

DIMENSIONS

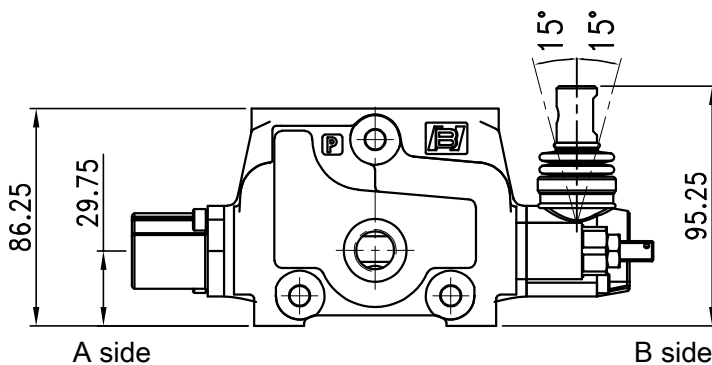
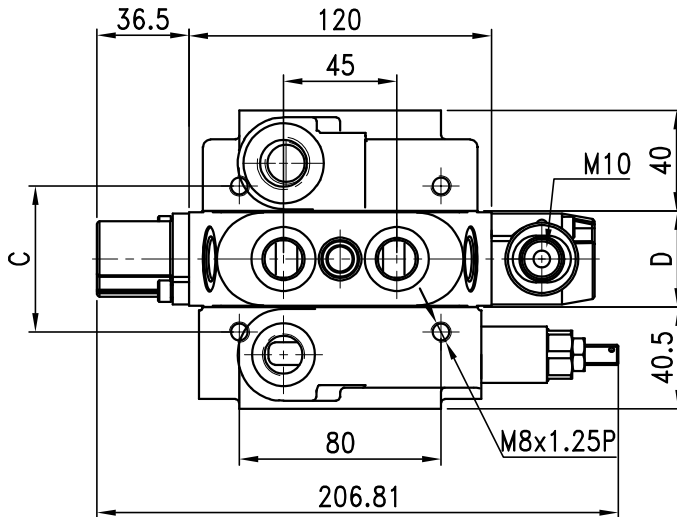

Type	Dimensions	
	C	D
MS-060/1	58	38
MS-060/2	96	76
MS-060/3	134	114
MS-060/4	172	152
MS-060/5	210	190
MS-060/6	248	228
MS-060/7	286	266
MS-060/8	324	304
MS-060/9	362	342
MS-060/10	400	380
MS-060/11	438	418
MS-060/12	476	456

unit : mm

PERFORMANCE

Nominal flow rating : 45 l/min

Operating pressure (Max.) : parallel or tandem circuit : 315 bar
 series circuit : 210 bar

Back pressure (Max.): 25 bar (on outlet port T)

Oil leaks from A (B) to T: 3 c.c./min at 100 bar (1450 psi)

Fluid: best use mineral oil with viscosity ranging between 15 to 75 mm²/s

Fluid temperature : Min. -20°C , Max 80°C ,with NBR (BUNA-N) gaskets
 Min. -20°C ,Max 100°C ,with FPM (VITON) seals gaskets

MS-060

RATING DIAGRAM

Open centre
From side inlet to side outlet

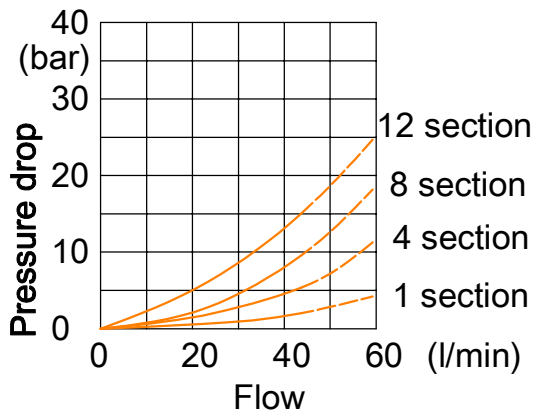

Inlet to work port
From side inlet to A port (spool in position 1) or B port (spool in position 2)

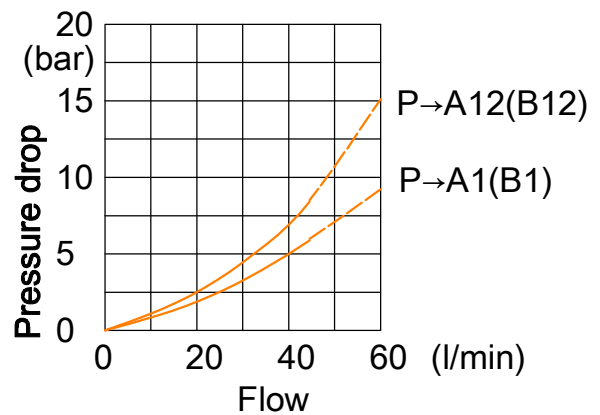

Work port to outlet
From A port (spool in position 2) or B port (spool in position 1) to side outlet

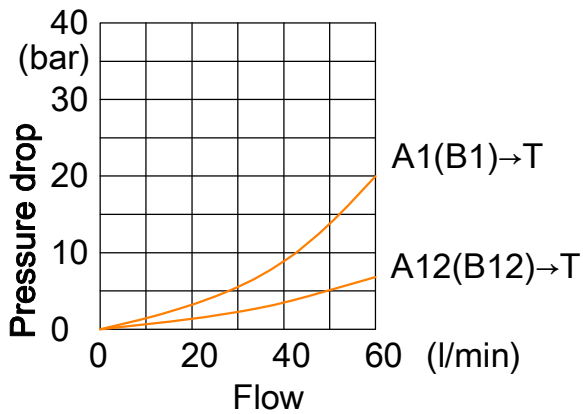

1 to 12 section

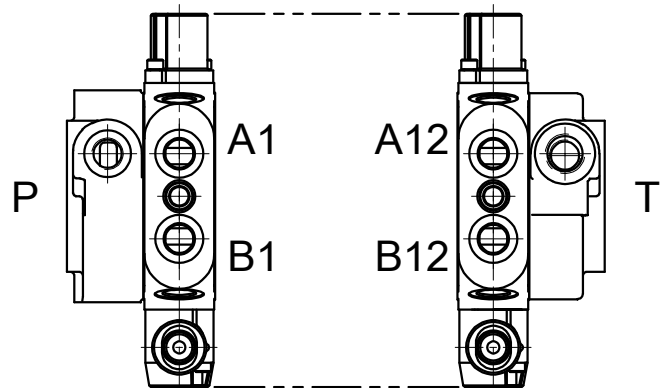



SYSTEM OF FLUID POWER

MS-060

ORDERING CODE NUMBER EXAMPLE

MS-060/2/ L - S - A (S - 200) / PB / PC / ^{1st section} A1 PP - NA /

工作片 1. 2. 3. 4. 5. 6. 7. 8. 9. 10. 11. 12.

數量 / L1 A2 E1 - AR(1-50) / SAE / ECK1/2-CS01

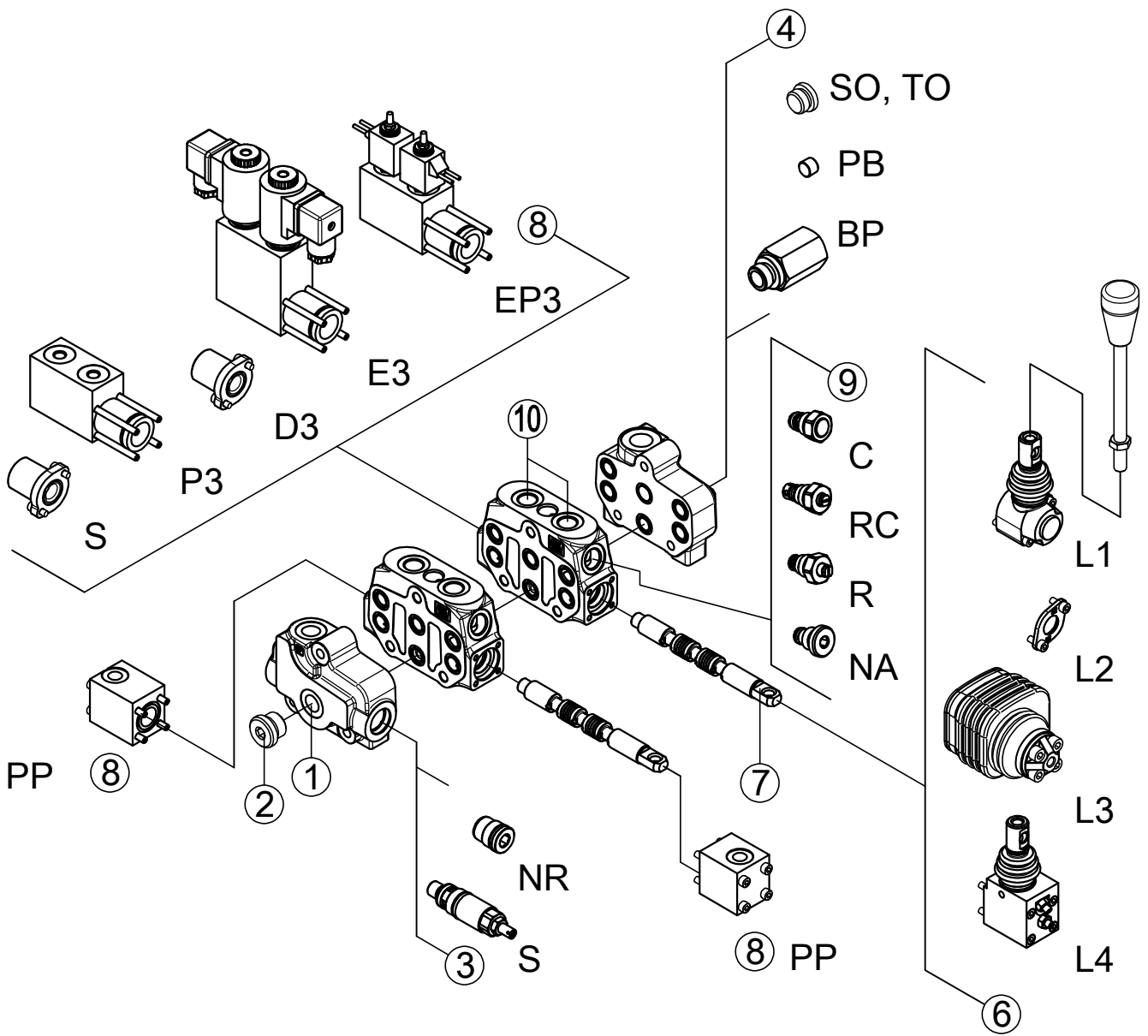



MS-060

ORDERING CODE NUMBER EXAMPLE

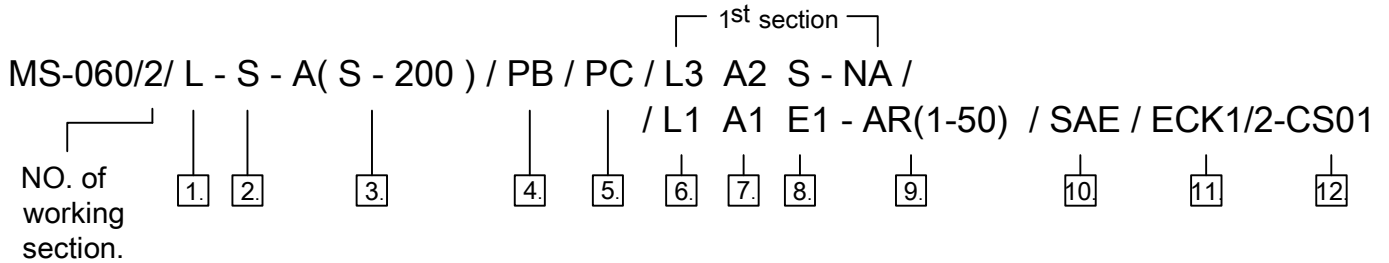

1. Inlet alimentation page.49

Type	Description
L	Left side alimentation
R	Right side alimentation

2. Inlet cover page.50

Type	Description
S	Side inlet.
T	Top inlet.

3. Inlet cover main relief valve page.51

Type	Description
NR (D-200)	Relief valve blanking plug. Direct-acting relief valve, range 200 to 315 bar/ 2900 to 4570 psi. standard setting 220 bar / 3200psi.
(DL-200)	Direct-acting relief valve with capping, range 200 to 315bar/ 2900 to 4570 psi. standard setting 220 bar / 3200psi.

4. Outlet cover page.52

Type	Description
PB	Top outlet with power beyond.
CC	Top outlet with closed center.
SO	Side outlet to tank.
BP	Back pressure option.
TO	Top outlet to tank.

5. Hydraulic circuit page.55

Type	Description
PC	Parallel circuit.
TC	Tandem circuit.

6. "B" side option page.56

Type	Description
L1	Standard lever aluminum pivot box. with neoprene gatieer.
L1A	Standard lever with an extra screw to adjust either side of spool stroke.
L2	Without lever with L2 dust cover.
L3	joystick lever(+axis) with left fulcrum.
L4	Standard lever set as L1A, able to adjust both side of spool stroke.

7. Spool option page.57

Type	Description
A1	Double acting,3 positions with A and B closed in centre.
A2	Double acting,3 positions with A and B open to tank in neutral position.
2A	Double acting,3 positions with A open to tank in neutral position.
2B	Double acting,3 positions with B open to tank in neutral position.
A3	Single acting on A,3 position.B plugged.
A4	Single acting on B,3 position.A plugged.

8. "A" side spool positioners page.58

Type	Description
S	Spring return to neutral.
SA	Adjust single side of spool stroke.
P3	Spring return to neutral. On/off pneumatic control. Min. pressure 5 bar(70 psi) Max. pressure 10 bar (140 psi).
D1R	Detent in positions1.Spring return to neutral.
D2R	Detent in positions2.Spring return to neutral.
D12R	Detent in positions 1 or 2.Spring return to neutral.
D3	Detent in three positions.



MS-060

ORDERING CODE NUMBER EXAMPLE

8."A" side spool positioners page.58

Type	Description
LH1	External hydraulic pilot to position 1. Spring return to neutral.
LH2	external hydraulic pilot to position 2. Spring return to neutral.
LH3	external hydraulic pilot to position 1 and 2. Spring return to neutral.
E1	On/off electro-hydraulic control with extrnal pilot and solenoid function to position 1.Spring return to neutral.
E2	On/off electro-hydraulic control with extrnal pilot and solenoid function to position 2.Spring return to neutral.
E3	On/off electro-hydraulic control with extrnal pilot and solenoid function to position 1 and 2.Spring return to neutral.
EP1	On/off electro-pneumatic control with extrnal pilot and solenoid function to position 1. Spring return to neutral.
EP2	On/off electro-pneumatic control with extrnal pilot and solenoid function to position 2. Spring return to neutral.
EP3	On/off electro-pneumatic control with extrnal pilot and solenoid function to position 1 and 2. Spring return to neutral.
SW1	With spring return in neutral position, operation signalling in position 1 ,prearranged for centralized microswitch control.
SW2	With spring return in neutral position, operation signalling in position 2 ,prearranged for centralized microswitch control.
SW3	With spring return in neutral position, operation signalling in position 1 and 2, prearranged for centralized microswitch control.
PP	Proportional hydraulic control.

9.Port Relief valves page.62

Type	Description
NH	No cartridge cavities.
NA	No relief valve. (can be omitted)
A	Mounted on port A.
B	Mounted on port B.
C	Mounted on port A and B.
Relief valve	
R(1-50)	Range 20 to 80 bar/ 290 to 1160 psi. standard setting 50 bar / 725psi.
R(2-100)	Range 50 to 220 bar/ 725 to 3190 psi. standard setting 100 bar / 1450psi.
R(3-200)	Range 180 to 350 bar/ 2610 to 5076 psi. standard setting 200 bar / 2900psi.
Anti-shock valve	
RC(1-50)	Range 20 to 80 bar/ 290 to 1160 psi. standard setting 50 bar / 725psi.
RC(2-100)	Range 50 to 220 bar/ 725 to 3190 psi. standard setting 100 bar / 145psi.
RC(3-200)	Range 180 to 350 bar/ 2610 to 5076 psi. standard setting 200 bar / 2900psi.
Anti-cavitation valve	
C	Anti-cavitation

10.Port threads option page.71

Type	Description
BSP	G.
SAE	UN-UNF.

11.EL control pilot kit page.65

Type	Description
ECK1/1-12	Compele kit with pressure reducing valve, manifold and pipes. (1-12 sections)
ECK2/1-12	Manifold kit and pressure reducing valve for connection to the main circuit.(1-12 sections)

12.Coil series page.66

Type	Description
CS01	Connection:A EN 175301-803 ISO 4400 (DIN.43650) Voltage : 12-24VDC
CS02	Connection:lead wires connection Voltage : 12-24VDC
CS03	Connection:AMP Junior connection Voltage : 12-24VDC
CS04	Connection:M27x1 connection Voltage : 12-24VDC
EP	Connection:lead wires connection Voltage : 12-24VDC ("A" side has to be used with EP)

MS-060

1. Inlet alimentation

Left inlet

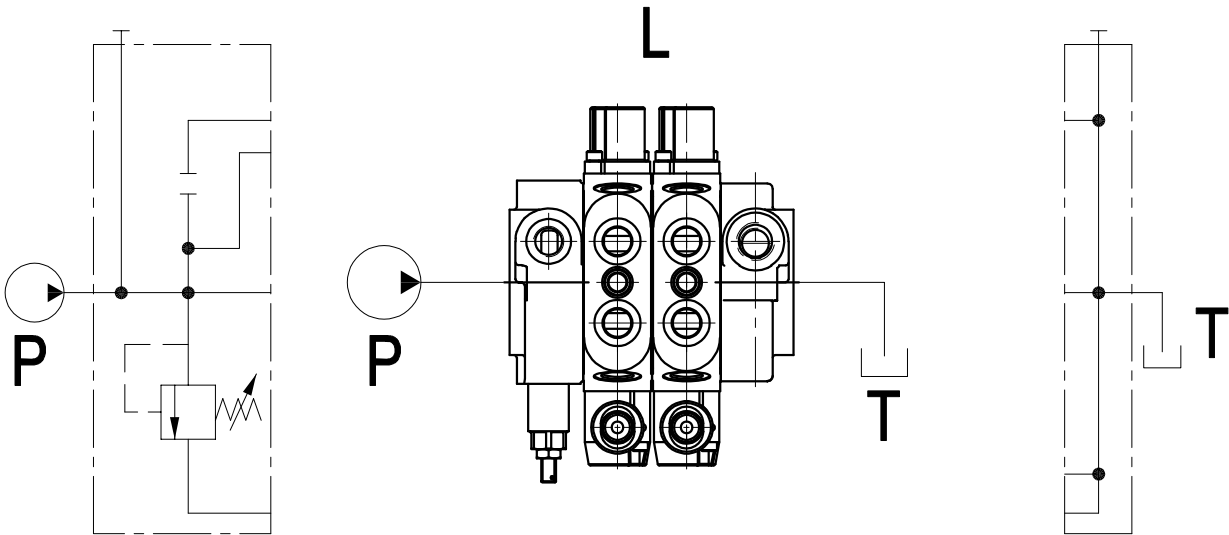

Right inlet

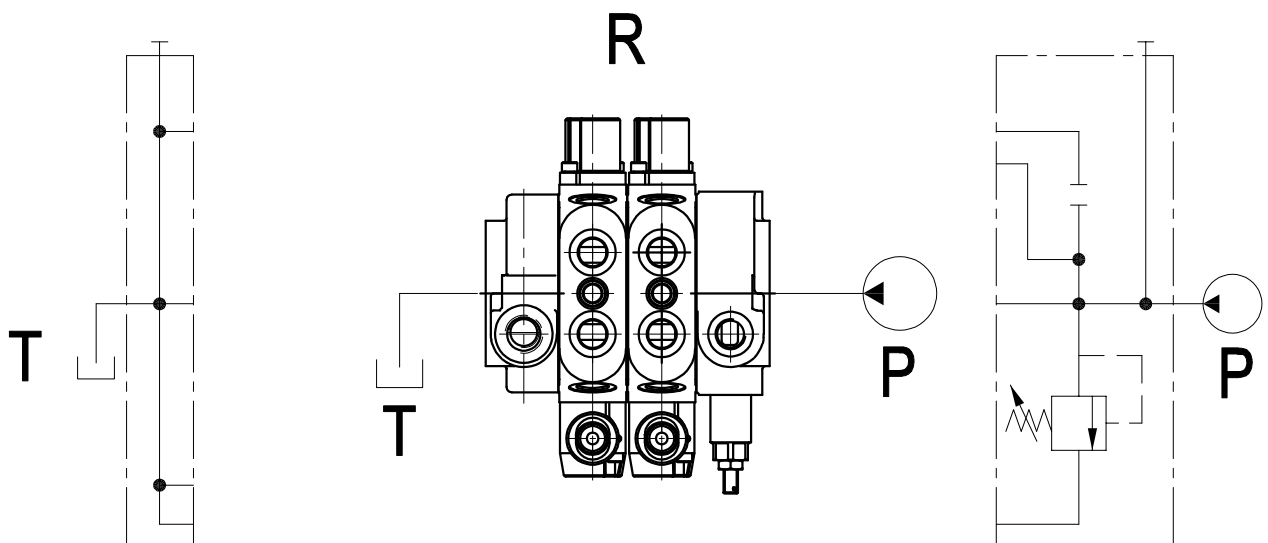

MS-060

2. Inlet cover

Inlet cover and position

Side inlet.

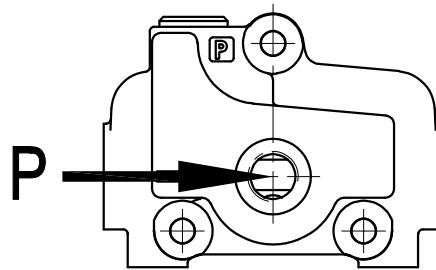
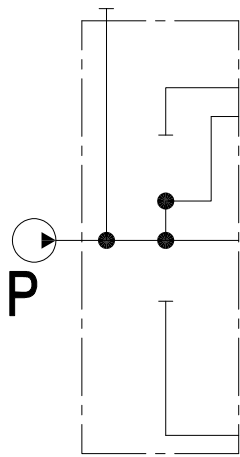

S

Top inlet.

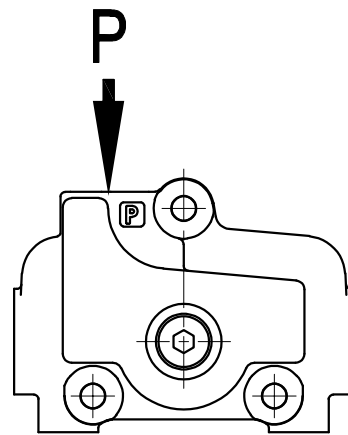
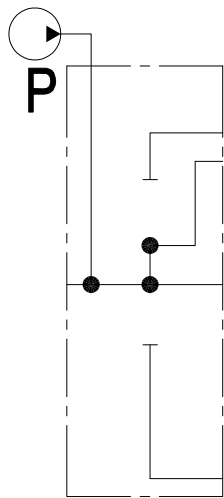

T

MS-060

3. Inlet cover main relief valve

Main relief valve position

A (D - 200)

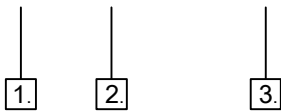

- 1. NR=None relief valve.
A=Mounted on port A.
B=Mounted on port B.
- 2. Main relief type(D)
Optional: with capping (DL)
- 3. D / DL :Standard pressure setting in
200~315bar.
Standard pressure 220bar/3200psi.

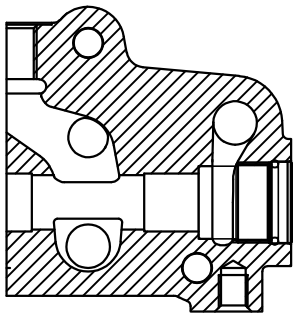

NR : Relief valve blanking plug

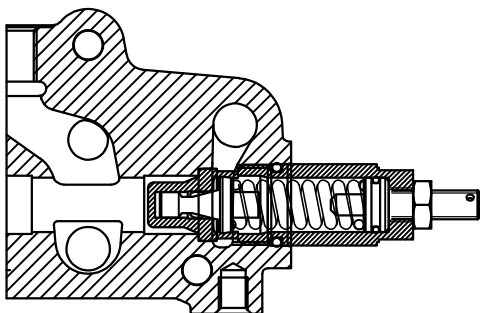

D : Direct-acting relief valve

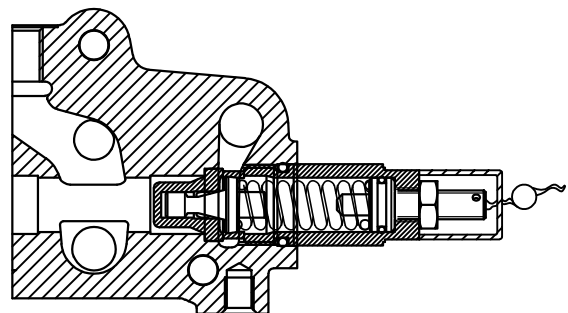

DL : Direct-acting relief valve
with capping

MS-060

4. Outlet cover

Outlet cover and position

Top outlet with power beyond

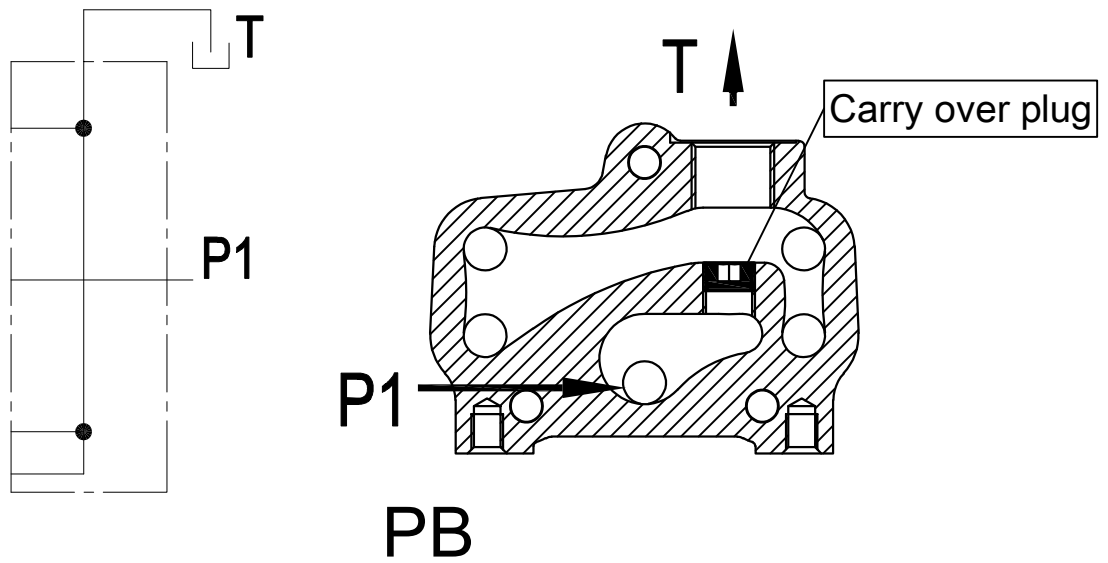

Top outlet with closed center

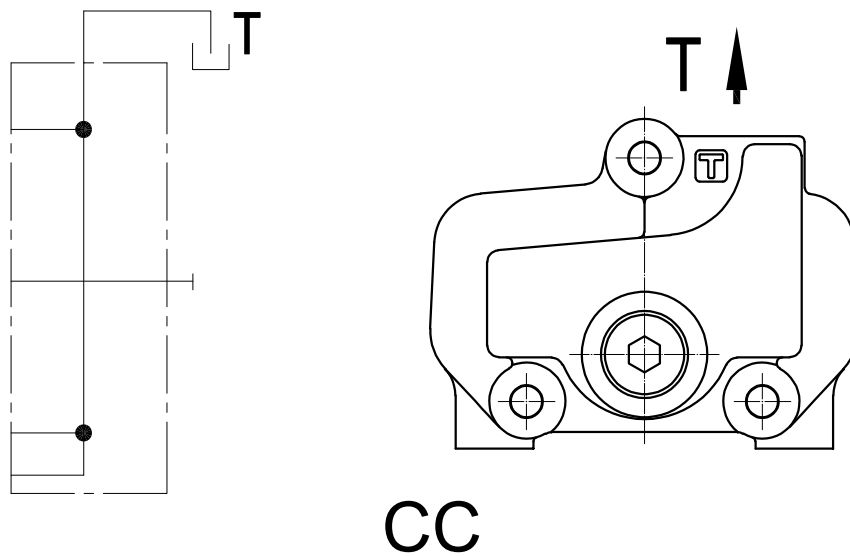

MS-060

4. Outlet cover

Outlet cover and position

Side outlet to tank

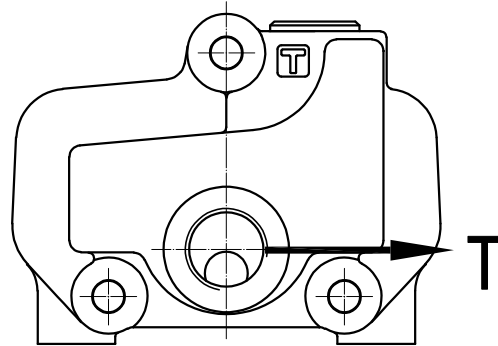
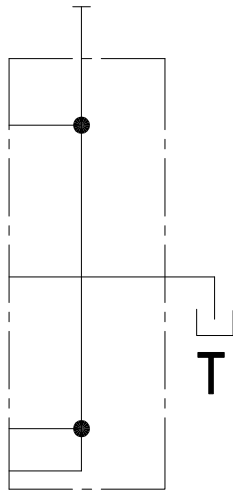

SO

Top outlet to tank

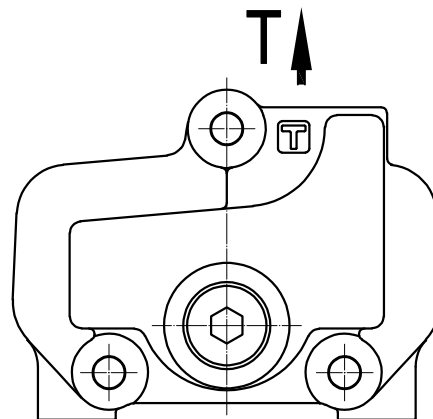
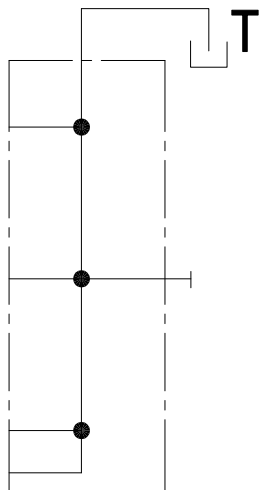

TO

MS-060

4. Outlet cover

Outlet cover and position

Back pressure option
(For use with electro-hydraulic control)

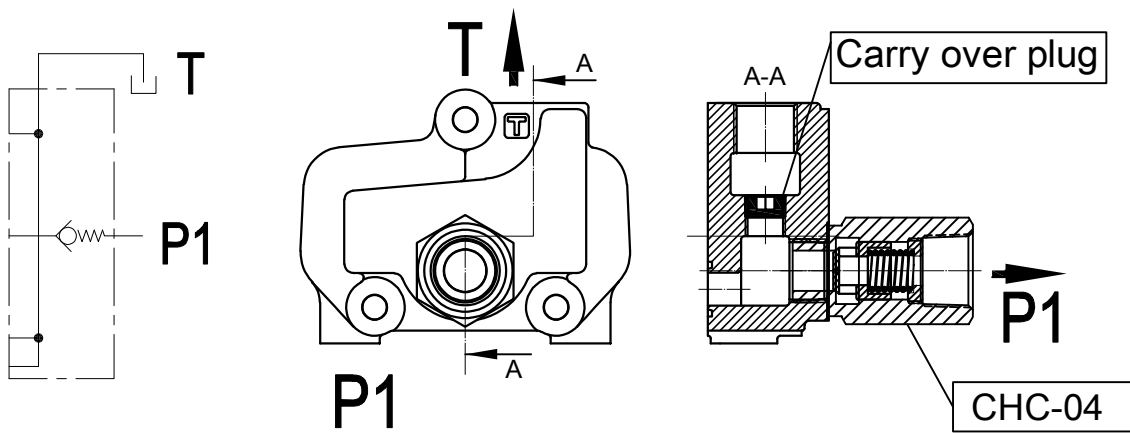

Carry-over with CHC-04 back pressure valve set at 10bar (145 psi) on the free line (side outlet). Used for electro-hydraulic controls.

BP

MS-060

5. Hydraulic circuit

Parallel circuit

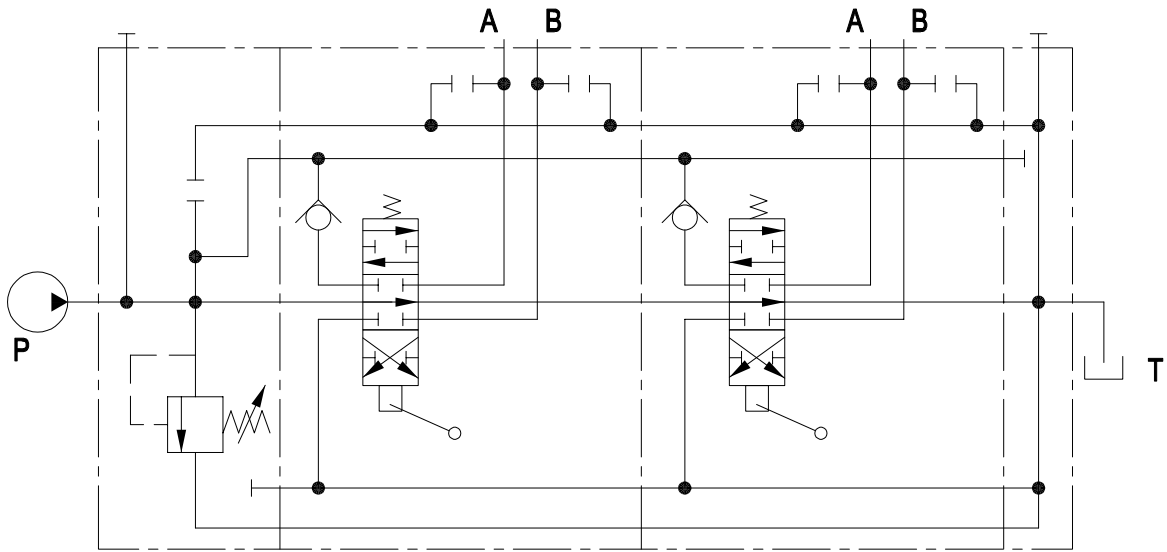

PC

Tandem circuit

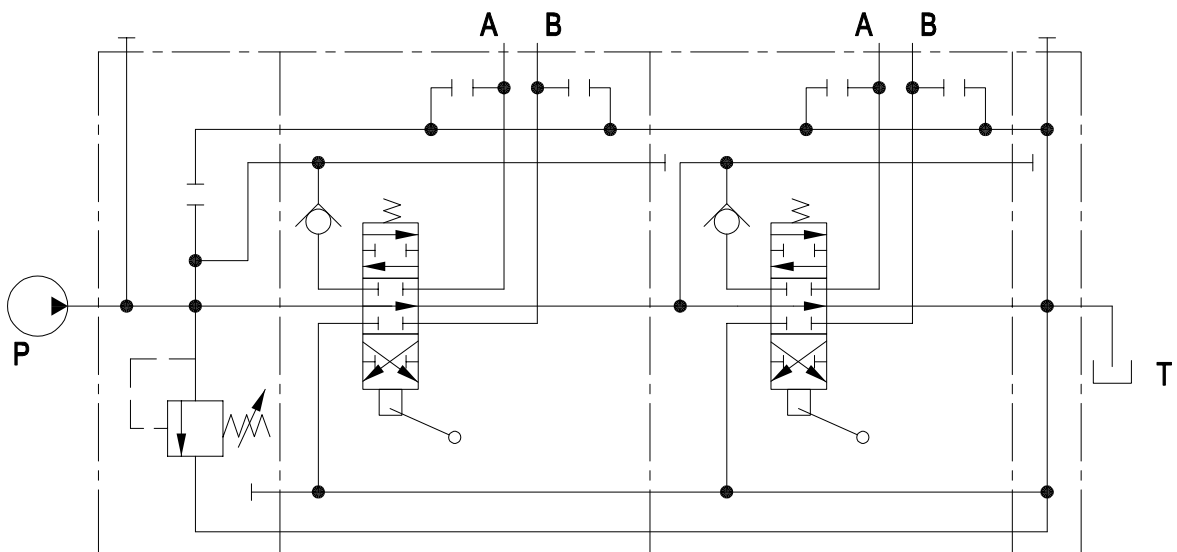

TC

MS-060

6. "B" side option

Spool control B port side

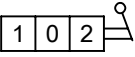
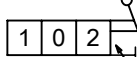
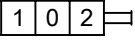
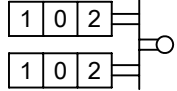
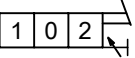
Type	Scheme	Description	Type	Scheme	Description
L1		Standard lever aluminum pivot box with neoprene gaiter.	L1A		Standard lever with an extra screw to adjust either side of spool stroke
L2		Without lever with L2 dust cover.	L3		"L3 of 4 Type" joystick lever(+ axis) with left fulcrum.
L4		Standard lever set as L1A, able to adjust both side of spool stroke			

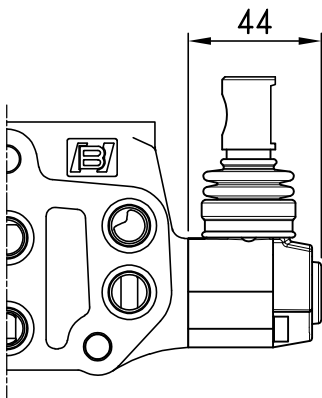

L1

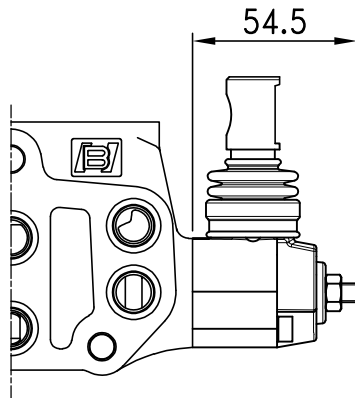

L1A

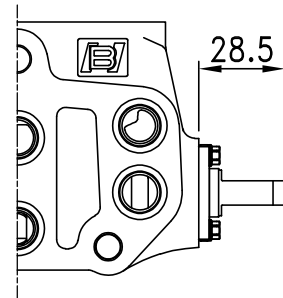

L2

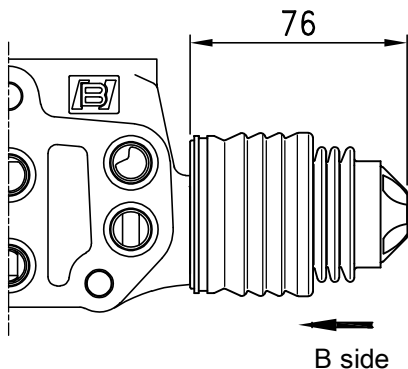

L3

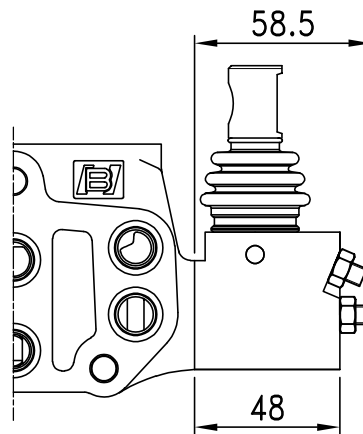

L4

MS-060

L3-1

View from B side

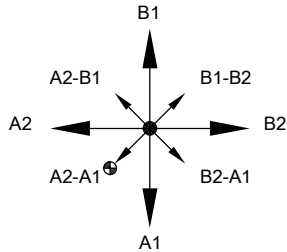

Bottom fulcrum

L3-3*

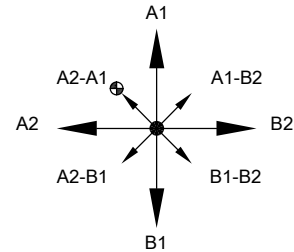

Top fulcrum

L3-2

View from B side

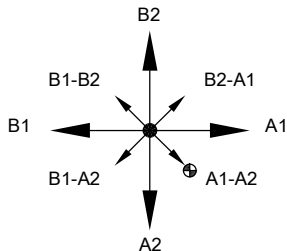

Bottom fulcrum

L3-4*

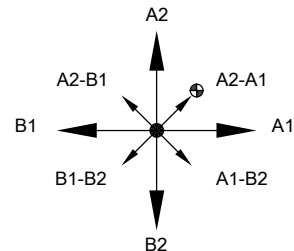

Top fulcrum

Note: * Configurations not available with service port valve.

7. Spool option

Spool

Type	Scheme
A1	
A2	
2A	
2B	
A3	
A4	

MS-060

8. "A" side spool positioners

Spool control A port side

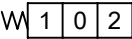
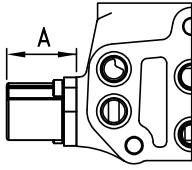
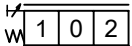
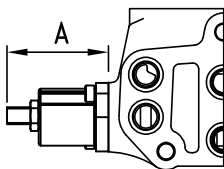
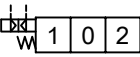
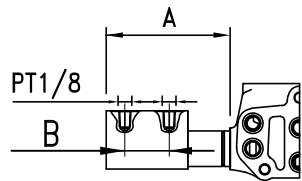
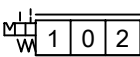
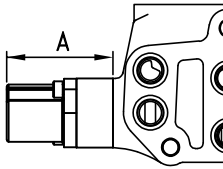
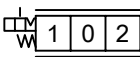
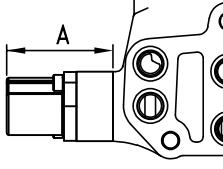
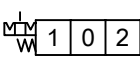
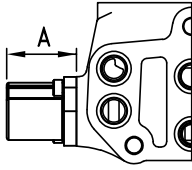
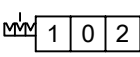
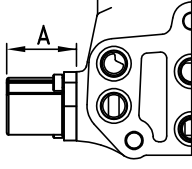
Type	Scheme	Description	Dimensions
S		S = Spring centered.	 37 (1.46)
SA		SA = Spring return to neutral. Adjust single side of spool stroke.	 52(MAX) (2.05)
P3		P = On/off pneumatic control Min. pressure 5 bar (70 psi) Max. pressure 10 bar (140 psi)	 A 106.5 (4.19) B 38 (1.5)
D1R		D1R = Detent in positions1. Spring return to neutral.	 68 (2.68)
D2R		D2R = Detent in position2. Spring return to neutral.	 68 (2.68)
D12R		D12R = Detent in positions1 or 2. Spring return to neutral.	 37 (1.46)
D3		D3 = Detent in three positions	 37 (1.46)

MS-060

8. "A" side spool positioners

Spool control A port side

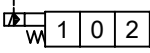
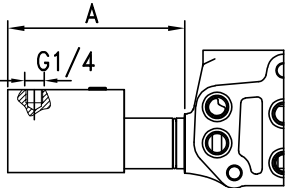
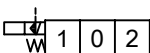
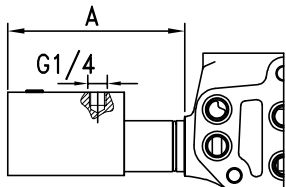
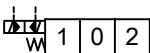
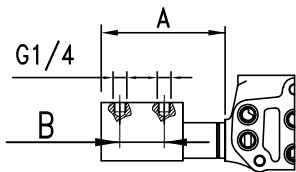
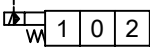
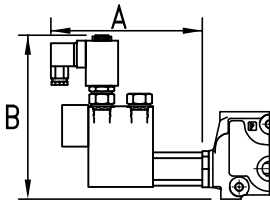
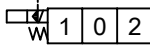
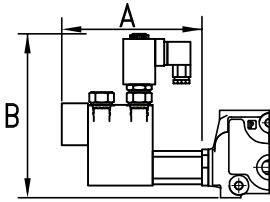
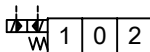
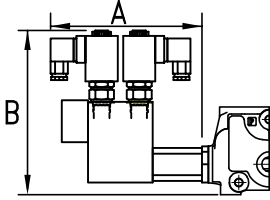
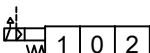
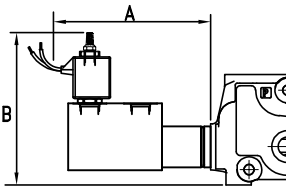
Type	Scheme	Description	Dimensions
LH1		LH1 = External hydraulic pilot to position 1. Spring return to neutral.	 106.5 (4.19)
LH2		LH2 = External hydraulic pilot to position 2. Spring return to neutral.	 106.5 (4.19)
LH3		LH3 = External hydraulic pilot to position 1 and 2. Spring return to neutral.	 A 106.5 (4.19) B 38 (1.5)
E1		E1=On/off electro-hydraulic control with external pilot and solenoid function to position 1. Spring return to neutral. Voltage: 12VDC, 24VDC	 A 150 (5.90) B 162 (6.40)
E2		E2=On/off electro-hydraulic control with external pilot and solenoid function to position 2. Spring return to neutral. Voltage: 12VDC, 24VDC	 A 140 (5.51) B 162 (6.40)
E3		E3=On/off electro-hydraulic control with external pilot and solenoid function to position 1 and 2. Spring return to neutral. Voltage: 12VDC, 24VDC	 A 150 (5.90) B 162 (6.40)
EP1		EP1=On/off electro-pneumatic control with external pilot and solenoid function to position 1. Spring centered. Voltage: 12VDC, 24VDC	 A 120 (4.72) B 120 (4.72)

MS-060

8. "A" side spool positioners

Spool control A port side

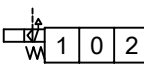
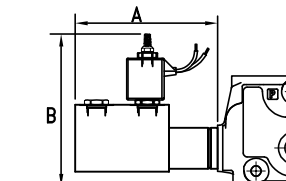
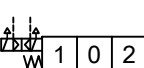
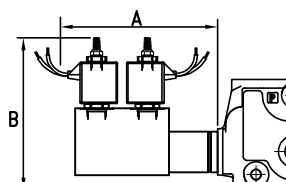
Type	Scheme	Description	Dimensions
EP2		EP2=On/off electro-pneumatic control with external pilot and solenoid function to position 2. Spring centered. Voltage:12VDC,24VDC	 <p>A 110 (4.33) B 120 (4.72)</p>
EP3		EP3=On/off electro-pneumatic control with external pilot and solenoid function to position 1 and 2. Spring centered. Voltage:12VDC,24VDC	 <p>A 120 (4.72) B 120 (4.72)</p>

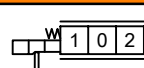
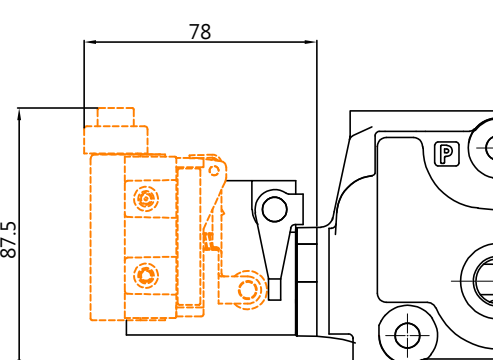
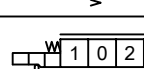
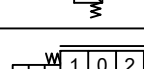
Type	Scheme	Description	Dimensions
SW1		SW1=With spring return in neutral position, operation signalling in position 1, prearranged for centralized microswitch control	 <p>78 87.5</p>
SW2		SW2=With spring return in neutral position, operation signalling in position 2, prearranged for centralized microswitch control	
SW3		SW3=With spring return in neutral position, operation signalling in position 1 and 2, prearranged for centralized microswitch control	

Spool control A and B-port side

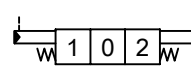
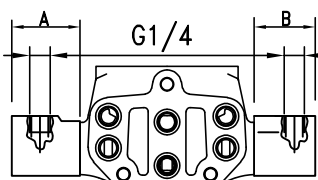
PP		PP = Proportional hydraulic control.	 <p>A 47.5 (1.87) B 42.5 (1.67)</p>
----	---	--------------------------------------	---

MS-060

9.Port Relief valves

Without Port Valve Prearrangement

L1 A2 S - NH

1. NH= No relieve port

1.

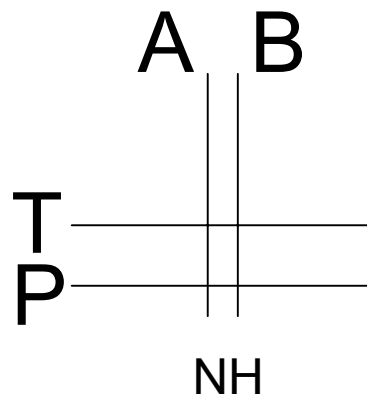
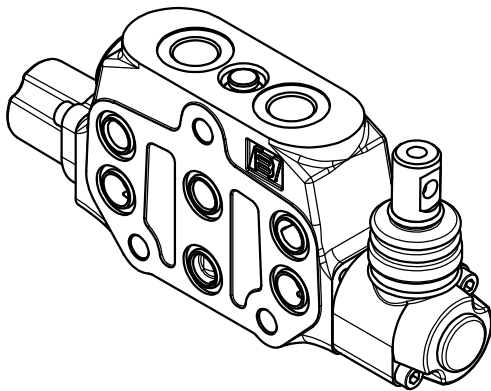

NH

With Port Valve Prearrangement

L1 A2 S - NA

1. NA= No relieve valve (can be omitted)

1.

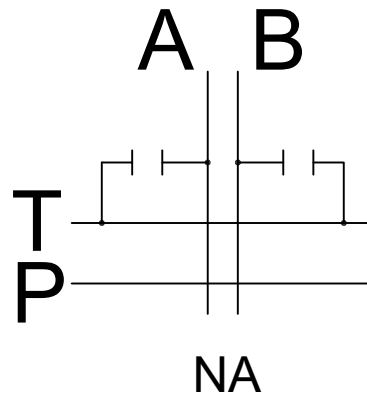
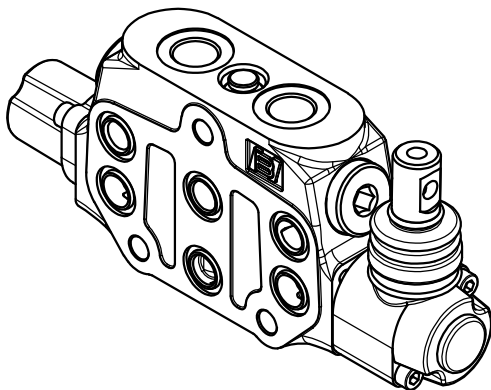

NA

MS-060

9.Port Relief valves

Anti-shock Valves

A R (2 - 100)

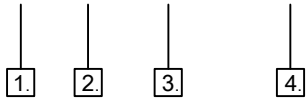

- 1. A= On A side
B= On B side
C= On both sides
- 2. Valve options
- 3. Spring options
- 4. Pressure setting

Spring type	01	02	03
Max. Pressure	80	220	350
Min. Pressure	20	50	180

unit : bar

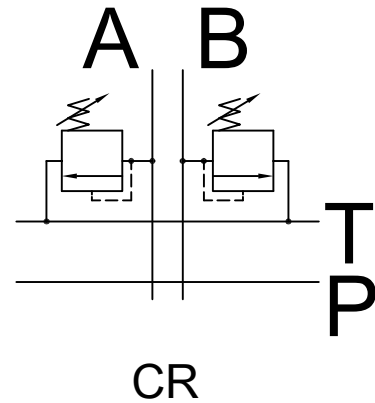
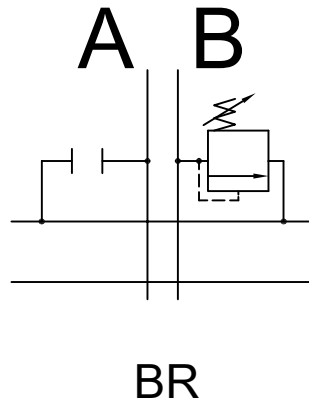
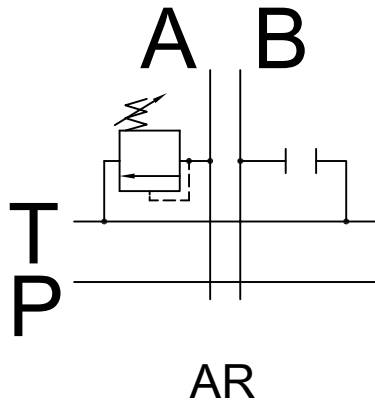

Anti-shock and Anti-cavitation Valves

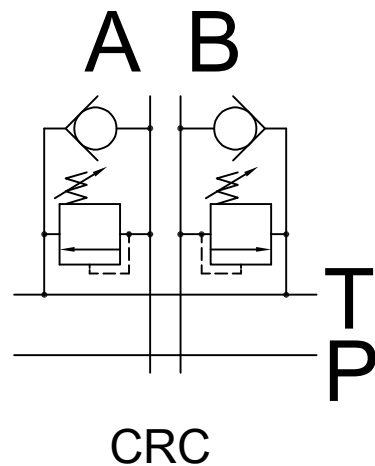
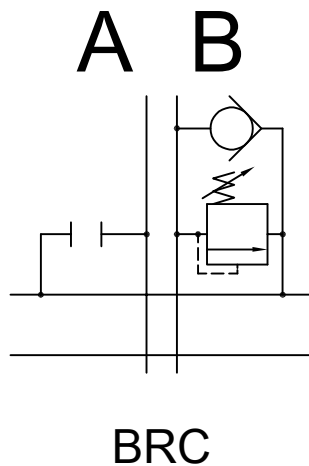
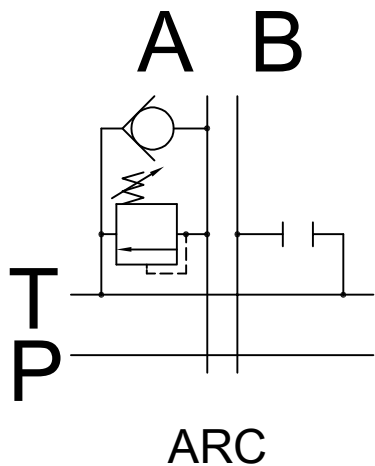

MS-060

9.Port Relief valves

Anti-cavitation Valves

L1 A2 S - A C



- 1. A=On A side
- B=On B side
- C=On both sides

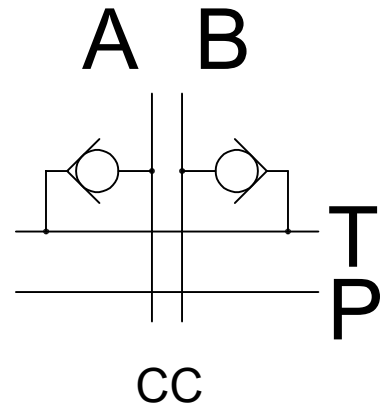
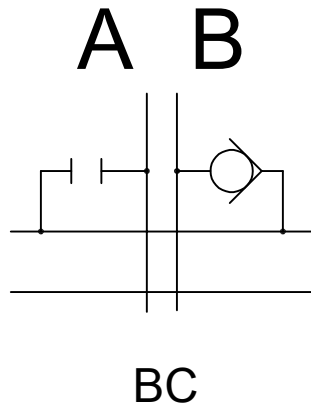
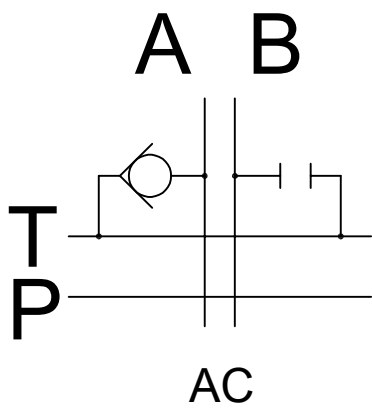

MS-060

10.EL control pilot kit

EL control pilot kit

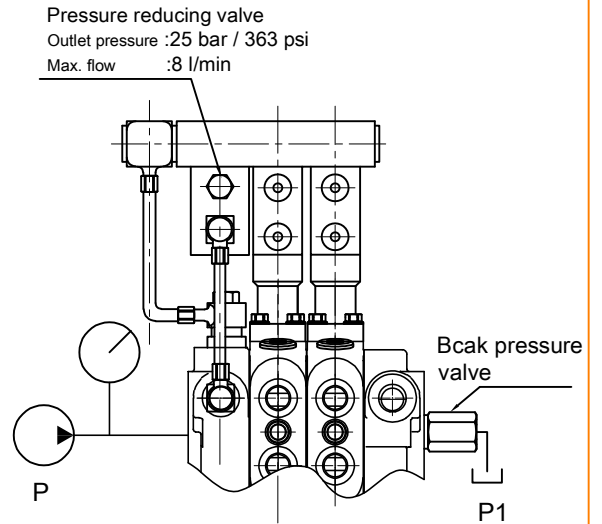
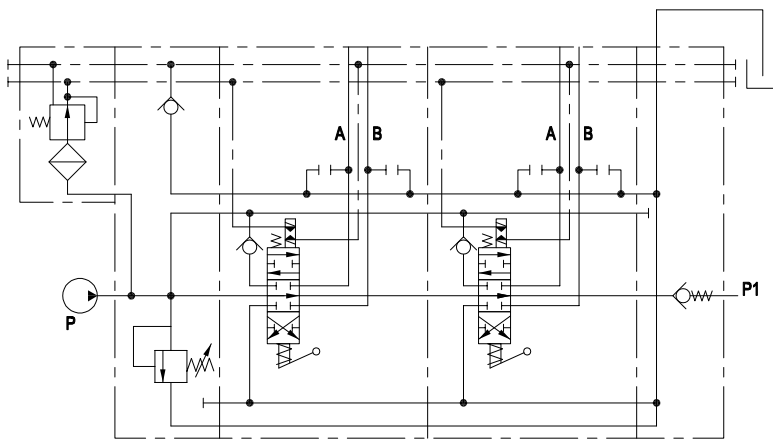

Complete kit with pressure reducing valve, manifold and pipes.

ECK1/1-12

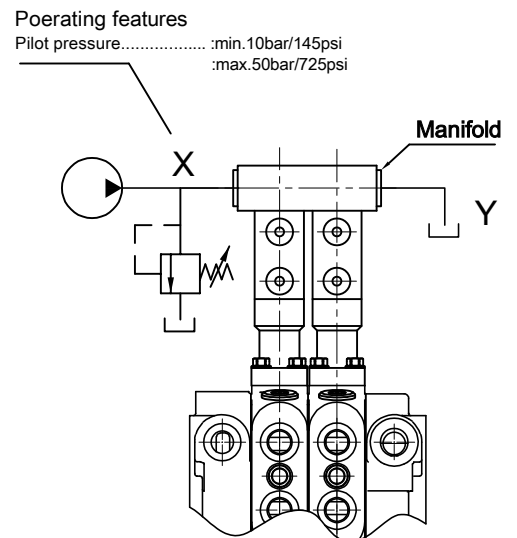
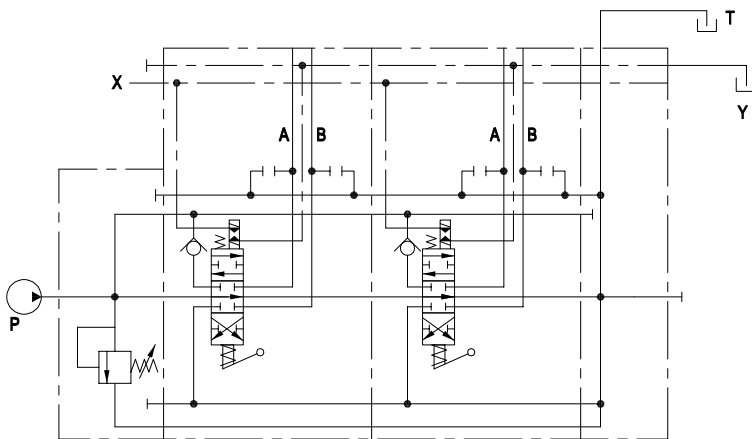

Manifold kit and pressure reducing valve for connection to the main circuit.

ECK2/1-12

MS-060

11. Coil Series

Coil series option

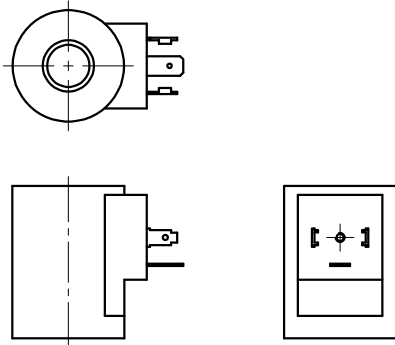

Type : CS01
 Connection=A EN 175301-803 ISO 4400(DIN.43650)
 Voltage : 12-24VDC

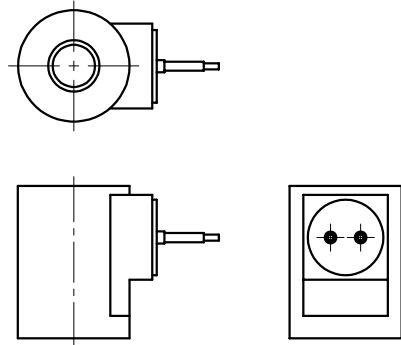

Type : CS02
 Connection=lead wires connection
 Voltage : 12-24VDC

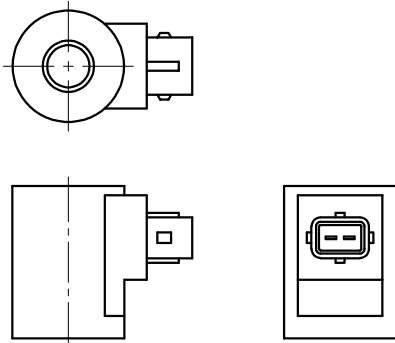

Type : CS03
 Connection=AMP Junior connection
 Voltage : 12-24VDC

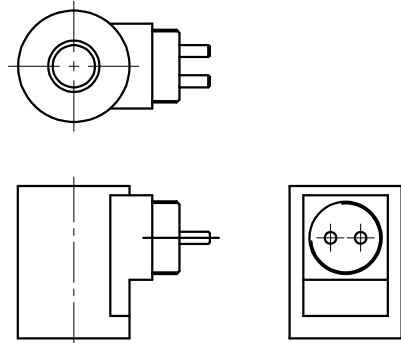

Type : CS04
 Connection=M27x1 connection
 Voltage : 12-24VDC

DIMENSIONS

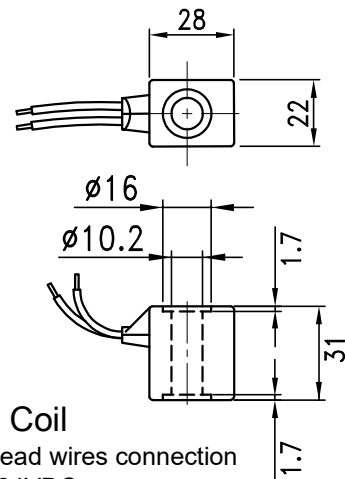
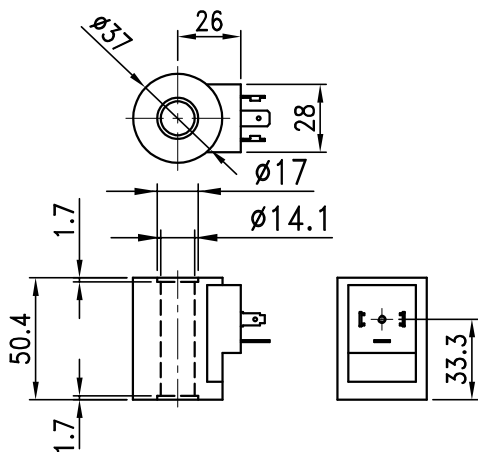

Type : EP Coil
 Connection=lead wires connection
 Voltage : 12-24VDC



SYSTEM OF FLUID POWER

MS-060

ORDERING CODE NUMBER EXAMPLE

MS-060-Outlet cover
IC-MS-060/L-S-A(S-200)-BSP

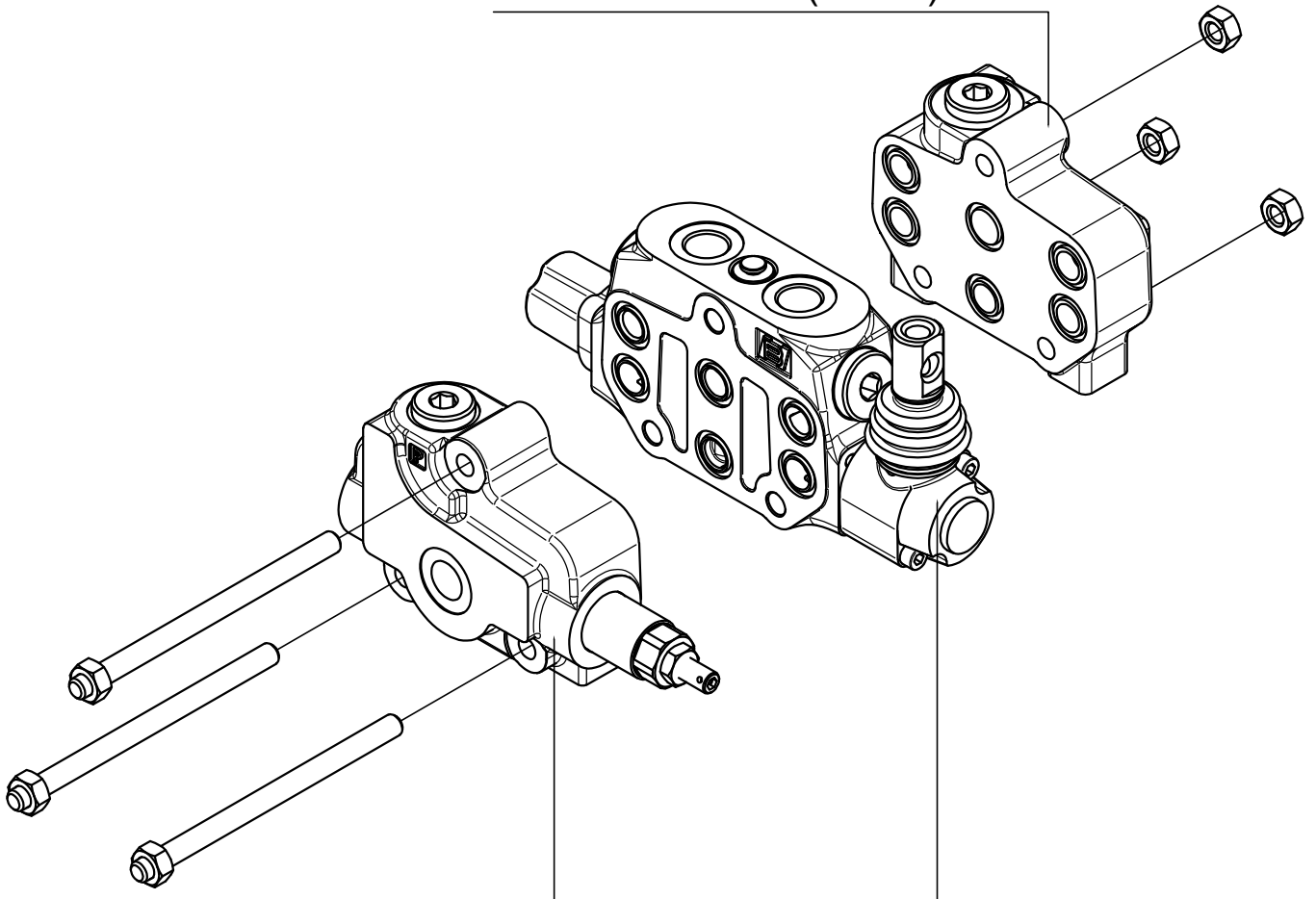

MS-060-Inlet cover
IC-MS-060/L-S-A(S- 200)-BSP

MS-060-Working section
WS-MS-060/L1A A1-PC-SA-AR(1-50)-BSP - CS01

MS-060-Working section

ORDERING CODE NUMBER EXAMPLE

WS-MS-060/ 1. 2. - 3. - 4. - 5. - 6. - 7.

WS
(Working Section)

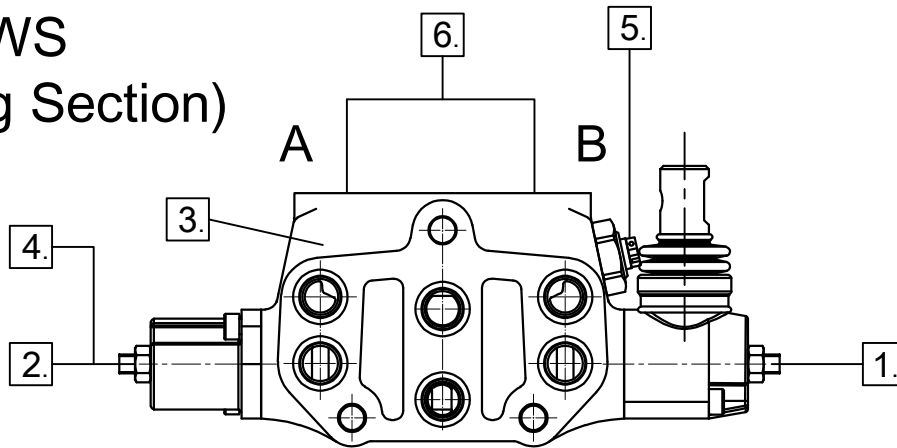

1."B" side option page.56

Type	Description
L1	Standard lever aluminum pivot box. with neoprene gatie.
L1A	Standard lever with an extra screw to adjust either side of spool stroke.
L2	Without lever with L2 dust cover.
L3	joystick lever(+axis) with left fulcrum.
L4	Standard lever set as L1A, able to adjust both side of spool stroke.

4."A" side spool positioners page.58

Type	Description
S	Spring return to neutral.
P	On/off pneumatic control. Min. pressure 5 bar(70 psi) Max. pressure 10 bar (140 psi).
D1R	Detent in positions1.Spring return to neutral.
D2R	Detent in positions2.Spring return to neutral.
D12R	Detent in positions 1 or 2.Spring return to neutral.
D3	Detent in three positions.
LH1	External hydraulic pilot to position 1. Spring return to neutral.
LH2	external hydraulic pilot to position 2. Spring return to neutral.
LH3	external hydraulic pilot to position 1 and 2. Spring return to neutral.
E1	On/off electro-hydraulic control with extrnal pilot and solenoid function to position 1.Spring return to neutral.
E2	On/off electro-hydraulic control with extrnal pilot and solenoid function to position 2.Spring return to neutral.
E3	On/off electro-hydraulic control with extrnal pilot and solenoid function to position 1 and 2.Spring return to neutral.

2.Spool option page.57

Type	Description
A1	Double acting,3 positions with A and B closed in centre.
A2	Double acting,3 positions with A and B open to tank in neutral position.
2A	Double acting,3 positions with A open to tank in neutral position.
2B	Double acting,3 positions with B open to tank in neutral position.
A3	Single acting on A,3 position.B plugged.
A4	Single acting on B,3 position.A plugged.

3.Hydraulic circuit page.55

Type	Description
PC	Parallel circuit.
TC	Tandem circuit.



MS-060-Working section

ORDERING CODE NUMBER EXAMPLE

4."A" side spool positioners page.58

Type	Description
EP1	On/off electro-pneumatic control with external pilot and solenoid function to position 1. Spring return to neutral.
EP2	On/off electro-pneumatic control with external pilot and solenoid function to position 2. Spring return to neutral.
EP3	On/off electro-pneumatic control with external pilot and solenoid function to position 1 and 2. Spring return to neutral.
SW1	With spring return in neutral position, operation signalling in position 1 ,prearranged for centralized microswitch control.
SW2	With spring return in neutral position, operation signalling in position 2 ,prearranged for centralized microswitch control.
SW3	With spring return in neutral position, operation signalling in position 1 and 2, prearranged for centralized microswitch control.
PP	Proportional hydraulic control.

6.Port threads option page.71

Type	Description
BSP	G.
SAE	UN-UNF.

7.Coil series page.66

Type	Description
CS01	Connection:A EN 175301-803 ISO 4400 (DIN.43650) Voltage : 12-24VDC
CS02	Connection:lead wires connection Voltage : 12-24VDC
CS03	Connection:AMP Junior connection Voltage : 12-24VDC
CS04	Connection:M27x1 connection Voltage : 12-24VDC
EP	Connection:lead wires connection Voltage : 12-24VDC ("A" side has to be used with EP)

5.Port Relief valves page.62

Type	Description
NH	No cartridge cavities.
NA	No relief valve. (can be omitted)
A	Mounted on port A.
B	Mounted on port B.
C	Mounted on port A and B.
Relief valve	
R(1-50)	Range 20 to 80 bar/ 290 to 1160 psi. standard setting 50 bar / 725psi.
R(2-100)	Range 50 to 220 bar/ 725 to 3190 psi. standard setting 100 bar / 1450psi.
R(3-200)	Range 180 to 350 bar/ 2610 to 5076 psi. standard setting 200 bar / 2900psi.
Anti-shock valve	
RC(1-50)	Range 20 to 80 bar/ 290 to 1160 psi. standard setting 50 bar / 725psi.
RC(2-100)	Range 50 to 220 bar/ 725 to 3190 psi. standard setting 100 bar / 145psi.
RC(3-200)	Range 180 to 350 bar/ 2610 to 5076 psi. standard setting 200 bar / 2900psi.
Anti-cavitation valve	
C	Anti-cavitation

MS-060-Inlet cover

ORDERING CODE NUMBER EXAMPLE

IC-MS-060/ L - S - A (S- 200) - BSP

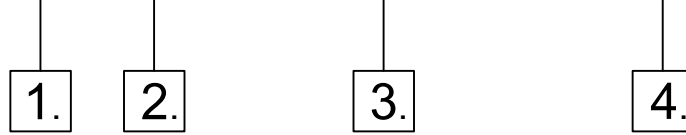

IC
(Inlet Cover)

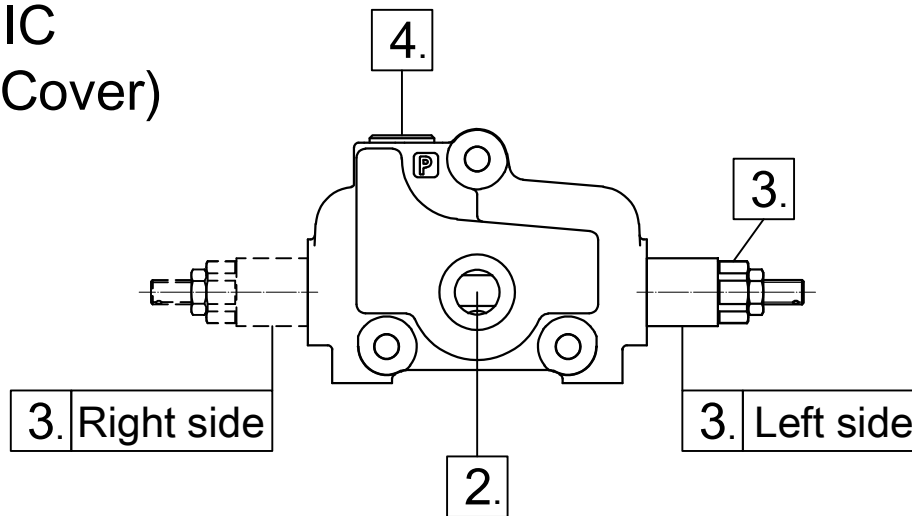

1. Inlet Alimentation page.49

Type	Description
L	Left side Alimentation
R	Right side Alimentation

2. Inlet cover page.50

Type	Description
S	Side inlet.
T	Top inlet.

3. Inlet cover relief valve page.51

Type	Description
NR	Relief valve blanking plug.
(D-200)	Direct-acting relief valve, range 200 to 315 bar/ 2900 to 4570 psi. standard setting 220 bar / 3200psi.
(DL-200)	Direct-acting relief valve with capping, range 200 to 315bar/ 2900 to 4570 psi. standard setting 220 bar / 3200psi.

4. Port threads option page.71

Type	Description
BSP	G.
SAE	UN-UNF.

MS-060-Outlet cover

ORDERING CODE NUMBER EXAMPLE

OC-MS-060/ CC - BSP

1.

2.

OC
(Outlet Cover)

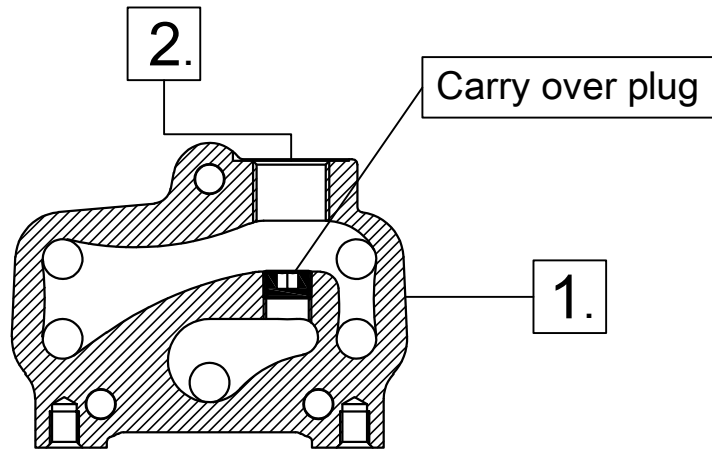

1.Outlet cover page.52

Type	Description
PB	Top outlet with power beyond.
CC	Top outlet with closed center.
SO	Side outlet to tank.
BP	Back pressure option.
TO	Top outlet to tank.

2.Port threads option page.71

Type	Description
BSP	G.
SAE	UN-UNF.

12.Port threads option

Port threads

PORT	BSP	SAE
P	G3/8	3/4-16UNF
A and B port	G3/8	9/16-18UNF
T	G1/2	3/4-16UNF