

CHECK SHUTTLE VALVES

CST-02

HYDRAULIC DIAGRAM

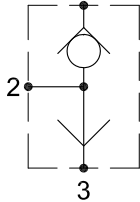

RATING DIAGRAM

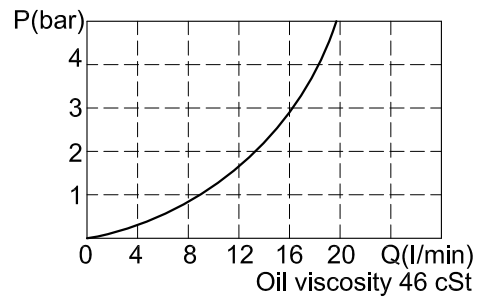

Qnom (L/min)	Pmax (Bar)	Pilot ratio
20	400	--

DIMENSIONS (mm)

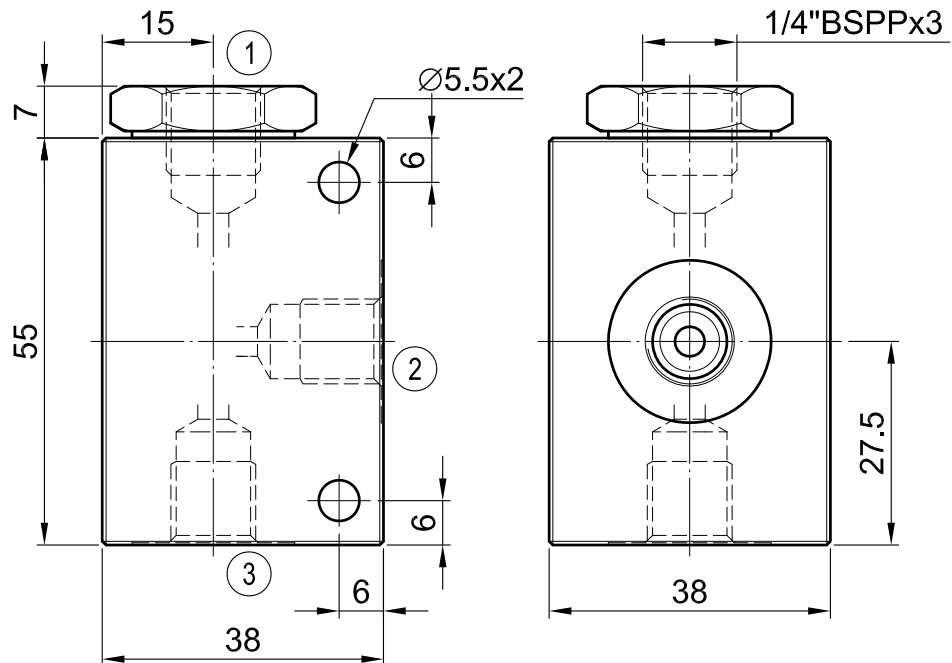

CST-02