

PRESSURE REDUCING VALVES

IPR-FJ

HYDRAULIC DIAGRAM

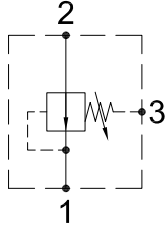

Type	Qnom (L/min)	Pmax (Bar)
IPR-FJ	60	350

RATING DIAGRAM

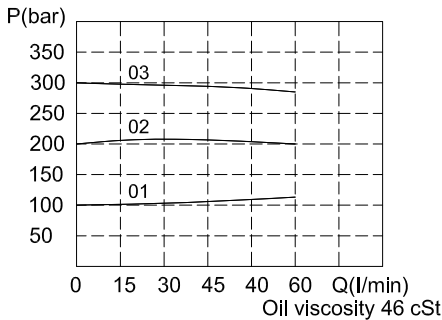

DIMENSIONS (mm)

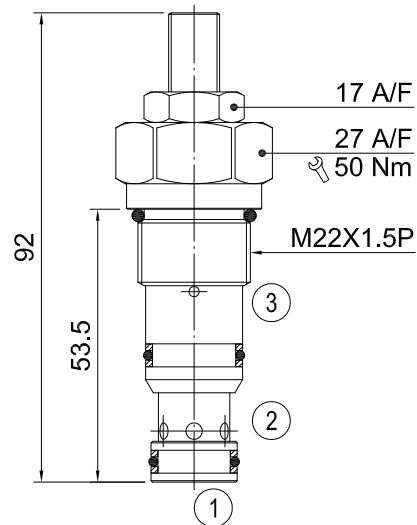

Cavities: see cavity data FJ-03

CODE NUMBER

IPR-FJ-01-L

Opening Pressure

Manual Adjustment

- 1) 01 = 10-100 BAR. Std setting 50 BAR
 - 2) 02 = 35-200 BAR. Std setting 100 BAR
 - 3) 03 = 50-350 BAR. Std setting 150 BAR
- (Std setting can be customised as requested. @6.8L/min)

(See Line Body Ordering)
Omit for standard
cartridge valves

■ APPLICATION

This valve is used to regulate the pressure of the pump's forked fluid line. It maintains the pressure which is persistent and lower than the fluid origin not to affect the main fluid line.

■ OPERATION

This valve is a normal open type. The spool's flow regulation or close maintains the main system's pressure. The fluid floating causes the pilot pressure to generate pressure difference (port 2 to port 1) and then causes the unbalanced pressure of the two sides of the spool. The spool flow changes from big to small or closes to reduce the pressure.

■ PERFORMANCE

Rated Flow : 60 l/min Max. pressure : 350 bar
Working temperature :
Min. -20°C, Max. 90°C, with standard BUNAN gaskets
Min. -20°C, Max. 120°C, with optional VITON gaskets on request

■ RECOMMENDATIONS

Fluid: best use mineral oil with viscosity ranging between 10 and 200 cSt
Filter: 25 micron or better
Cavities: see cavity data FJ-03
Installation: before screwing the cartridge on the valve body, ascertain to provide suitable gasket lubrication with clean oil and also be sure to screw the cartridge manually in to reach against the gaskets in the valve body.

H B HYDRAULICS CO., LTD. reserves the variations and modifications of technical features and dimensions;
and also reserves the right to stop production of each and any model listed in the catalogue with no notice.