

## CHECK SHUTTLE VALVES

### IST-08

#### HYDRAULIC DIAGRAM

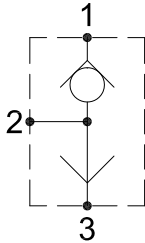

Type	Qnom (L/min)	Pmax (Bar)
IST-08	15	350

#### RATING DIAGRAM

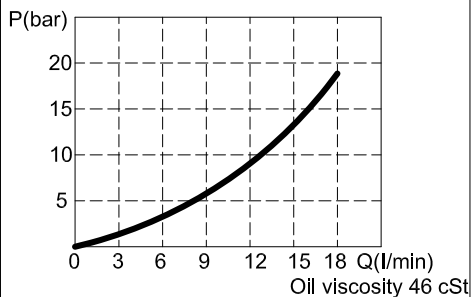

#### DIMENSIONS (mm)

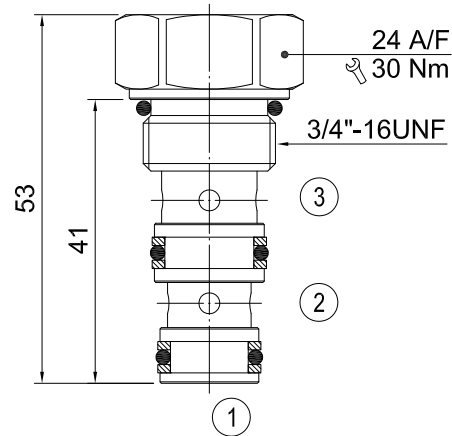

Cavities: see cavity data 08-03

#### CODE NUMBER

**IST-08**

#### ■ APPLICATION

This valve provides a means of sensing the higher pressures between two lines on a hydraulic circuit allowing this line to be used for an auxiliary function, such as the removal of a mechanically applied brake, the operation of a gauge or to give a remote pressure sensing line for the control of another independent valve.

#### ■ OPERATION

When a higher pressure is sensed at inlet port 1 than at inlet port 3 the ball within the cartridge is forced against a seat opening the higher pressure to outlet port 2. When the higher pressure appears at inlet port 3 the ball is forced against another seat which blocks inlet port 1 and opens up inlet port 3 to outlet port 2.

#### ■ PERFORMANCE

Rated Flow: 15 l/min Max. pressure: 350 bar  
 Working temperature:  
 Min. -20°C, Max. 90°C, with standard BUNAN gaskets  
 Min. -20°C, Max. 120°C, with optional VITON gaskets on request

#### ■ RECOMMENDATIONS

**Fluid:** best use mineral oil with viscosity ranging between 10 and 200 cSt  
**Filter:** 25 micron or better  
**Cavities:** see cavity data 08-03  
**Installation:** before screwing the cartridge on the valve body, ascertain to provide suitable gasket lubrication with clean oil and also be sure to screw the cartridge manually in to reach against the gaskets in the valve body.

H B HYDRAULICS CO., LTD. reserves the variations and modifications of technical features and dimensions; and also reserves the right to stop production of each and any model listed in the catalogue with no notice.