

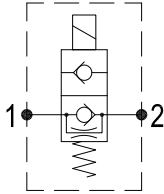

SYSTEM OF FLUID POWER  
SOLENOID VALVES

## ISC-08-N0

### HYDRAULIC DIAGRAM



Type	Qnom (L/min)	Pmax (Bar)
ISC-08-N0	20	280

### RATING DIAGRAM

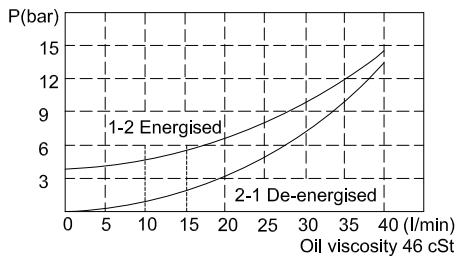

### DIMENSIONS (mm)

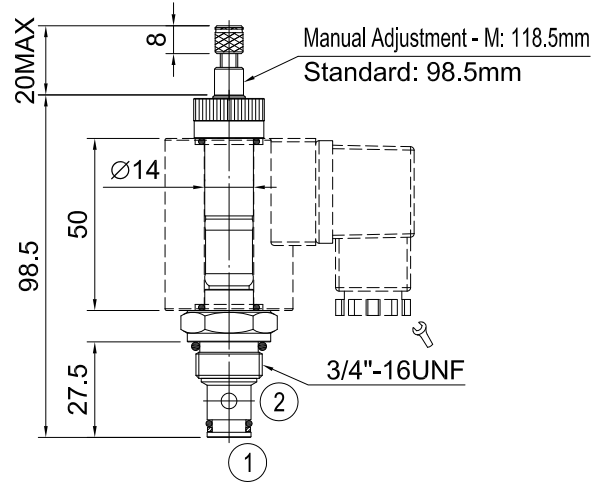

Cavities: see cavity data 08-02

### CODE NUMBER

#### ISC-08-N0-RA1-M

Type of Spool  
Normally Open

Voltage Available

Manual Adjustment  
Omit for standard cartridge valves

- 1) RA1 = 110 VRAC
- 2) RA2 = 220 VRAC
- 3) D1 = 12 VDC
- 4) D2 = 24 VDC

\*All AC coils must be used with a rectifying connector.

### ■ APPLICATION

To give on-off control of flows of 20 litres/min (5.3 US GPM) and pressure up to 280 bar (4000 psi). Typical usage includes the control of actuators in a hydraulic system.

### ■ OPERATION

With the valve version and de-energised solenoid, the oil flow is free from port 2 to port 1 but port 1 to port 2 restricted. When the solenoid is energised, the flow can be from port 1 to port 2, but stopped from port 2 to port 1.

### ■ PERFORMANCE

Rated Flow : 20 l/min Max. pressure : 280 bar  
Oil leaks from port 2 to port 1: 0.30 ml/min (5 dpm) at 210 bar and oil viscosity of 46 cSt when the solenoid is energised  
Working temperature :  
Min. -20°C, Max. 90°C, with standard BUNAN gaskets  
Min. -20°C, Max. 120°C, with optional VITON gaskets on request

### ■ RECOMMENDATIONS

**Fluid:** best use mineral oil with viscosity ranging between 10 and 200 cSt  
**Filter:** 25 micron or better  
**Cavities:** see cavity data 08-02  
**Installation:** before screwing the cartridge on the valve body, ascertain to provide suitable gasket lubrication with clean oil and also be sure to screw the cartridge manually in to reach against the gaskets in the valve body.

H B HYDRAULICS CO., LTD. reserves the variations and modifications of technical features and dimensions; and also reserves the right to stop production of each and any model listed in the catalogue with no notice.