

SOLENOID VALVES

IS-08-NC

HYDRAULIC DIAGRAM

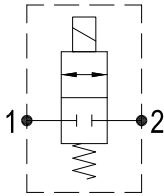

Type	Qnom (L/min)	Pmax (Bar)
IS-08-NC	15	210

RATING DIAGRAM

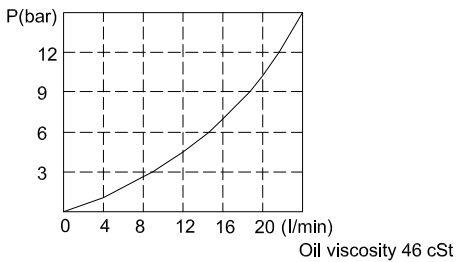

DIMENSIONS (mm)

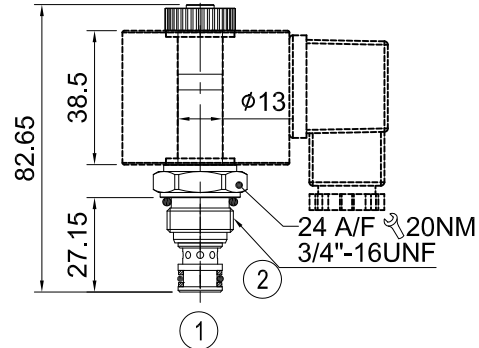

Cavities: see cavity data 08-02

CODE NUMBER

IS-08-NC-A1

Type of Spool
Normally Closed

Voltage Available

- 1) A1 = 110 VAC
- 2) A2 = 220 VAC
- 3) D1 = 12 VDC
- 4) D2 = 24 VDC

APPLICATION

To give on-off control of flows. Typical usage includes the control of actuators in a hydraulic system.

OPERATION

With the valve version and de-energised solenoid, the oil flow is stopped from port 1 to port 2 and is closed from port 2 to port 1 as well. When the solenoid is energised, the flow is free from port 2 to port 1 or port 1 to port 2.

PERFORMANCE

Rated Flow : 15 l/min Max. pressure : 210 bar
 Oil leaks from port 2 to port 1: 60 ml/min at 210 bar and oil viscosity of 46 cSt
 Working temperature :
 Min. -20°C, Max. 90°C, with standard BUNAN gaskets
 Min. -20°C, Max. 120°C, with optional VITON gaskets on request

RECOMMENDATIONS

Fluid: best use mineral oil with viscosity ranging between 10 and 200 cSt
Filter: 25 micron or better
Cavities: see cavity data 08-02
Installation: before screwing the cartridge on the valve body, ascertain to provide suitable gasket lubrication with clean oil and also be sure to screw the cartridge manually in to reach against the gaskets in the valve body.