

OVERCENTRE VALVES

## IOC-CJ

### HYDRAULIC DIAGRAM

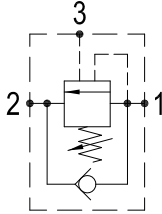

Type	Qnom (L/min)	Pmax (Bar)
IOC-CJ	30	350

### RATING DIAGRAM

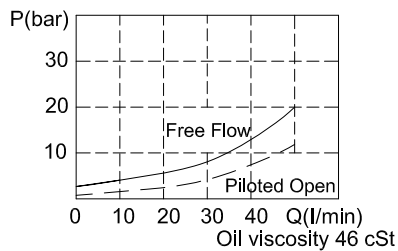

### DIMENSIONS (mm)

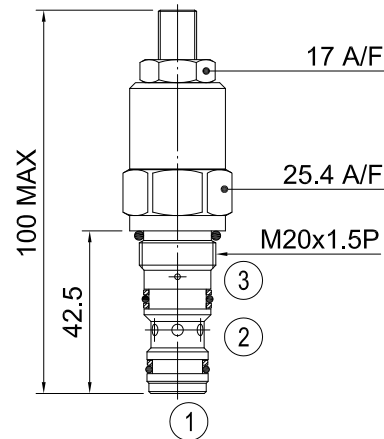

Cavities: see cavity data CJ-03

### CODE NUMBER

**IOC-CJ-01-P4.5**

Opening Pressure

Pilot Ratio 4.5:1

1) 01 = 50-200 BAR. Std setting 100 BAR

2) 02 = 180-350 BAR. Std setting 210 BAR

(Std setting can be customised as requested. @6.8L/min)

### APPLICATION

When the overcentre valve is assembled at the bottom of the cylinder or near the cylinder, when the fluid line bursts and the pump hasn't been operated but the directional valve is started accidentally, the valve would start the loading and remain at the original position and then generate safe control. The relief function of the overcentre valve can supply the losing of speed control or cavitation made by fluid protection which is needed by heat swelling. Overcentre valves offer a standard control to avoid the speed of loading is bigger than the pump flow.

### OPERATION

The design of check valve allows the fluid enter the cylinder free from port 2 to port 1. In opposite, from port 1 to port 2, it must be higher than the setting pressure then the flow appears. Or it's generated by the pilot pressure (port 3). The pilot pressure of the valve must be [setting pressure - loading pressure] + pilot ratio. The setting pressure is normally 1.3 times than the max. loading pressure.

### PERFORMANCE

Rated Flow : 30 l/min Max. pressure : 350 bar  
 Leakage : 0.3 ml/min (5 dpm)  
 Working temperature :  
 Min. -20°C, Max. 90°C, with standard BUNAN gaskets  
 Min. -20°C, Max. 120°C, with optional VITON gaskets on request

### RECOMMENDATIONS

**Fluid:** best use mineral oil with viscosity ranging between 10 and 200 cSt  
**Filter:** 25 micron or better  
**Cavities:** see cavity data CJ-03  
**Installation:** before screwing the cartridge on the valve body, ascertain to provide suitable gasket lubrication with clean oil and also be sure to screw the cartridge manually in to reach against the gaskets in the valve body.

H B HYDRAULICS CO., LTD. reserves the variations and modifications of technical features and dimensions; and also reserves the right to stop production of each and any model listed in the catalogue with no notice.