



SYSTEM OF FLUID POWER

PILOT CHECK VALVES

IPC-10

HYDRAULIC DIAGRAM

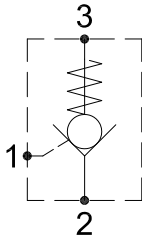

| Type | Qnom (L/min) | Pmax (Bar) |
|--------|--------------|------------|
| IPC-10 | 30 | 350 |

RATING DIAGRAM

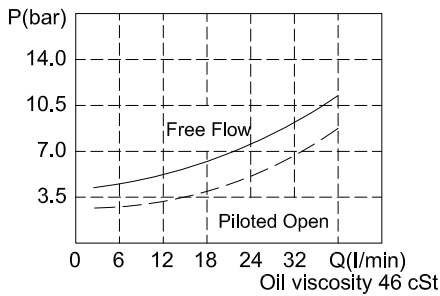

DIMENSIONS (mm)

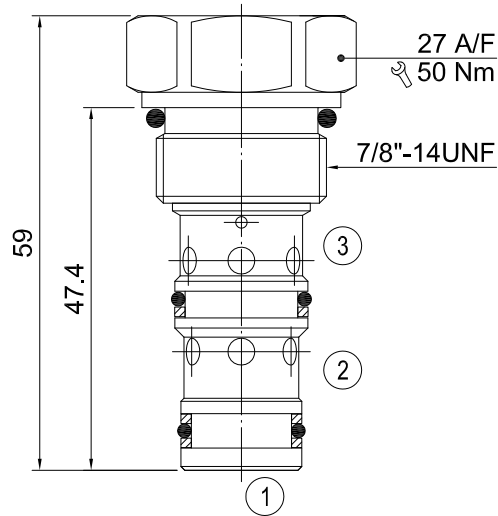

Cavities: see cavity data 10-03

CODE NUMBER

IPC-10-P3

Pilot Ratio 3:1

■ APPLICATION

Pilot check valves allow flow to pass in one direction, with a low pressure drop, then prevent reverse flow until pilot pressure is applied. There are many applications for this valve type, the most common being to lock and hold a cylinder, or another hydraulic actuator, in position. The IPC-10 is a small cartridge valve and is ideally suited for fitting directly into a cylinder, giving economy of installation, direct control of movement.

■ OPERATION

The oil flow is permitted from port 2 to port 3 and stopped in the opposite direction. A free oil flow from port 3 to port 2 is strictly possible when the pilot pressure in port 1 is enough to release the valve poppet. The minimum release pressure can be figured by dividing pressure in port 1 by the pilot ratio. To assure best valve performance from port 3 to port 2, make sure that no counter pressure arises in port 2.

■ PERFORMANCE

Rated Flow : 30 l/min Max. pressure : 350 bar
 Leakage : 0.3 ml/min (5 dpm)
 Working temperature :
 Min. -20°C, Max. 90°C, with standard BUNAN gaskets
 Min. -20°C, Max. 120°C, with optional VITON gaskets on request

■ RECOMMENDATIONS

Fluid: best use mineral oil with viscosity ranging between 10 and 200 cSt
Filter: 25 micron or better
Cavities: see cavity data 10-03
Installation: before screwing the cartridge on the valve body, ascertain to provide suitable gasket lubrication with clean oil and also be sure to screw the cartridge manually in to reach against the gaskets in the valve body.

H B HYDRAULICS CO., LTD. reserves the variations and modifications of technical features and dimensions; and also reserves the right to stop production of each and any model listed in the catalogue with no notice.