

FLOW REGULATOR PRESSURE COMPENSATED VALVES

IFB-16

HYDRAULIC DIAGRAM

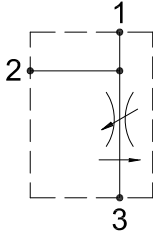

Type	Qnom (L/min)	Pmax (Bar)
IFB-16	150	350

DIMENSIONS (mm)

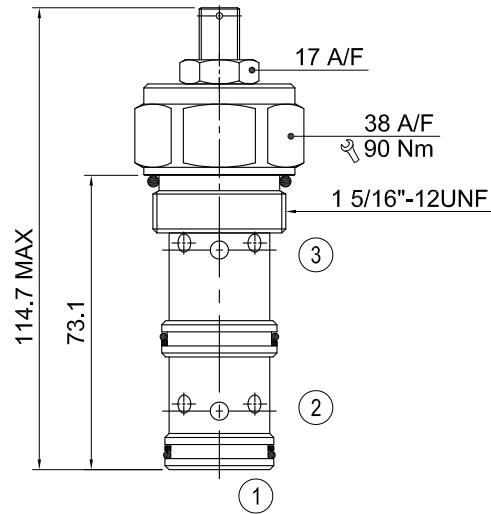

Cavities: see cavity data 16-03

RATING DIAGRAM

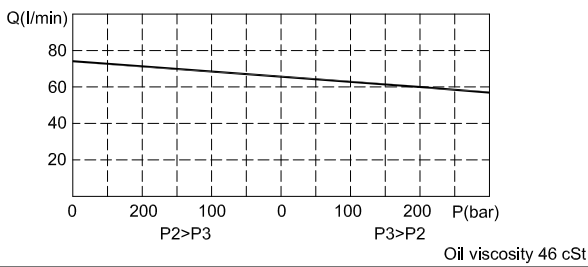

CODE NUMBER

IFB-16-L

Manual Adjustment
(See Line Body Ordering)
Omit for standard cartridge valves

■ APPLICATION

IFB series are priority flow regulators. If used to regulate flow from a fixed supply, the valve will pass the required flow and any surplus flow will be diverted to the bypass port. The bypass flow may be used for a secondary circuit.

■ OPERATION

This valve can adjust the flow volume from port 1 to port 3. With fixed flow, the pressure drop of damping is generated. The spring is moved by the force of the pressure which is generated by the pressure difference at the two sides of the spool. Whether the pressure requirement of port 2 is higher or lower than the pressure of port 3, the pressure of port 1 shall be higher than the pressure of port 2 or port 3.

■ PERFORMANCE

Rated Flow: 150 l/min Max. pressure: 350 bar
Working temperature:
Min. -20°C, Max. 90°C, with standard BUNAN gaskets
Min. -20°C, Max. 120°C, with optional VITON gaskets on request

■ RECOMMENDATIONS

Fluid: best use mineral oil with viscosity ranging between 10 and 200 cSt
Filter: 25 micron or better
Cavities: see cavity data 16-03
Installation: before screwing the cartridge on the valve body, ascertain to provide suitable gasket lubrication with clean oil and also be sure to screw the cartridge manually in to reach against the gaskets in the valve body.

H B HYDRAULICS CO., LTD. reserves the variations and modifications of technical features and dimensions; and also reserves the right to stop production of each and any model listed in the catalogue with no notice.