

CHECK VALVES

## IC-12

### HYDRAULIC DIAGRAM

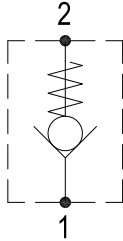

Type	Qnom (L/min)	Pmax (Bar)
IC-12	80	350

### RATING DIAGRAM

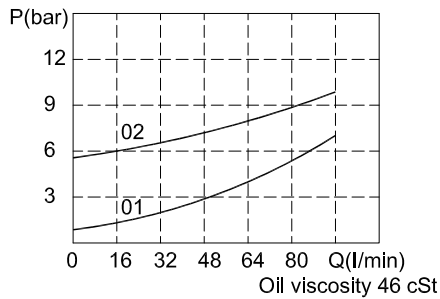

### DIMENSIONS (mm)

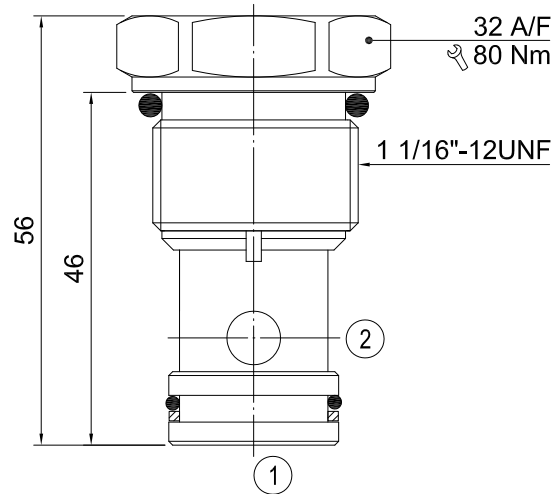

Cavities: see cavity data 12-02

### CODE NUMBER

**IC-12-01**

Opening Pressure

- 1) 01 = 0.5 BAR
- 2) 02 = 5 BAR

### ■ APPLICATION

These cartridge check valves allow flow at a low pressure drop, with cracking pressure from 0.5 to 5 bar in the free flow direction and close to prevent flow in the reverse direction.

### ■ OPERATION

Oil flow is permitted from port 1 to port 2 and close to prevent flow in the reverse direction.

### ■ PERFORMANCE

Rated Flow : 80 l/min Max. pressure : 350 bar  
 Opening pressure from port 1 to port 2: (1) 0.5 bar (2) 5 bar  
 Leakage : 0.3 ml/min (5 dpm)  
 Working temperature :  
 Min. -20°C, Max. 90°C, with standard BUNAN gaskets  
 Min. -20°C, Max. 120°C, with optional VITON gaskets on request

### ■ RECOMMENDATIONS

**Fluid:** best use mineral oil with viscosity ranging between 10 and 200 cSt  
**Filter:** 25 micron or better  
**Cavities:** see cavity data 12-02  
**Installation:** before screwing the cartridge on the valve body, ascertain to provide suitable gasket lubrication with clean oil and also be sure to screw the cartridge manually in to reach against the gaskets in the valve body.

H B HYDRAULICS CO., LTD. reserves the variations and modifications of technical features and dimensions; and also reserves the right to stop production of each and any model listed in the catalogue with no notice.