

CHECK SHUTTLE VALVES 梭動閥

CST-02

HYDRAULIC DIAGRAM 油路符號

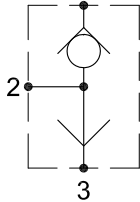

RATING DIAGRAM 流速表

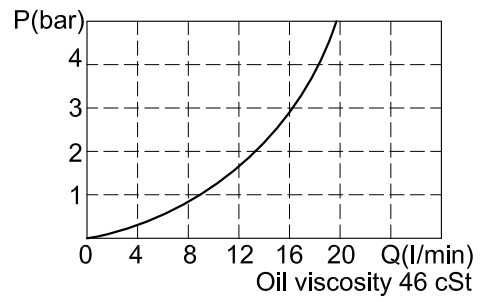

Qnom (L/min)	Pmax (Bar)	Pilot ratio
20	400	--

DIMENSIONS (mm) 尺寸

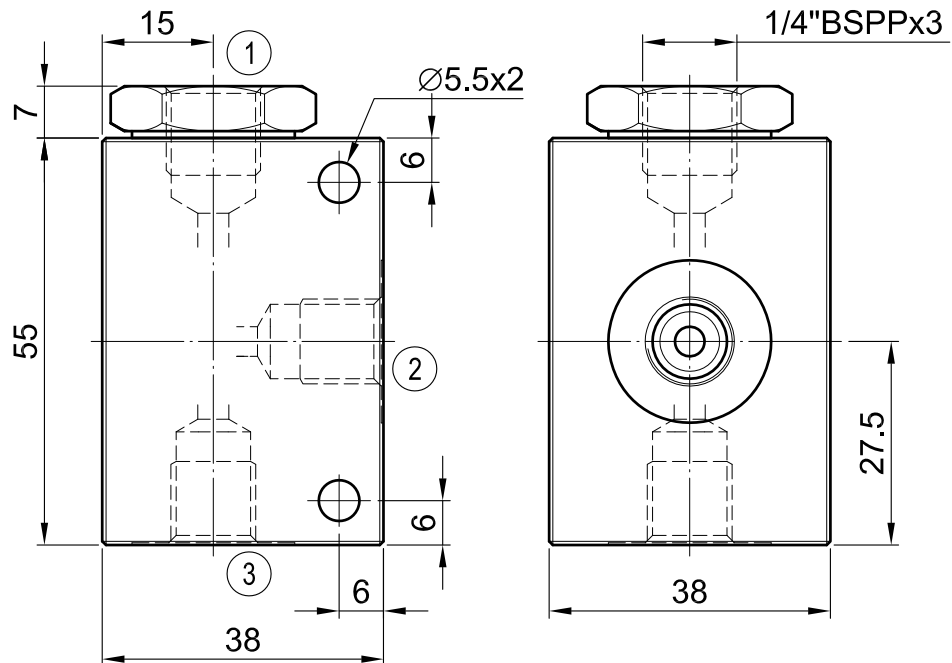

CST-02