



SYSTEM OF FLUID POWER

Coil Series 線圈

D13mm Coil series

D13 - 01 - 12 - 26

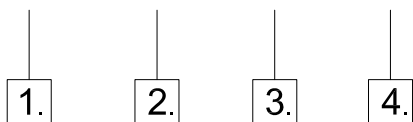

1. Coil Series 線圈  
D13=13mm  
D14=14mm  
D16=16mm

3. Voltage 電壓  
12 = 12VDC  
24 = 24VDC  
110 = 110VAC  
220 = 220VAC

2. Connection 連接器  
01=A EN 175301-803 ISO 4400(DIN.43650)  
02=Lead wires connection  
03=AMP Junior connection  
04=M27x1 connection  
05=Deutsch connection  
06=AMP super seal connection  
07=AMP super seal connection  
08=Deutsch connection  
4. Absorbed power 功率  
26 = DC Absorbed power 26 W  
(For D13,D14)  
28 = DC Absorbed power 28 W  
(For D16)

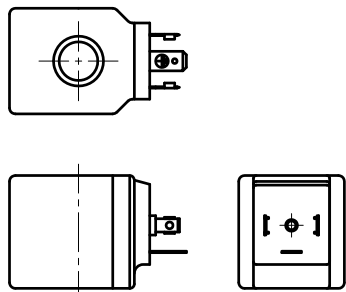

D13-01-12-26  
Connection=A EN 175301-803 ISO 4400(DIN.43650)  
電磁線圈

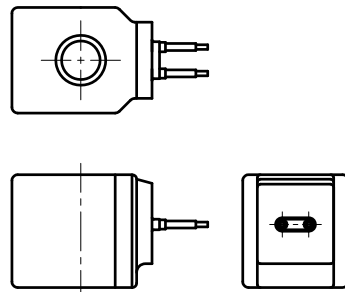

D13-02-24-26  
Connection=Lead wires connection  
出線型電磁線圈

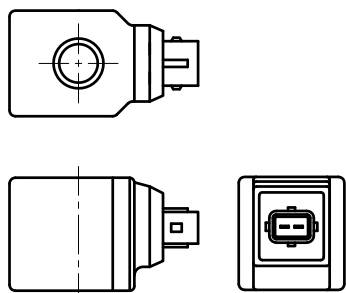

D13-03-24-26  
Connection=AMP Junior connection  
AMP初級電磁線圈

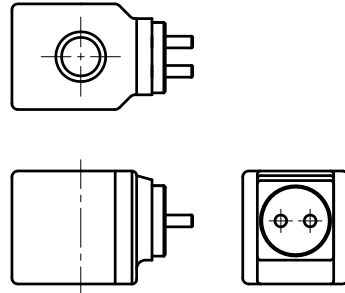

D13-04-24-26  
Connection=M27x1 connection  
M27x1 電磁線圈



SYSTEM OF FLUID POWER

Coil Series 線圈

D13mm Coil series

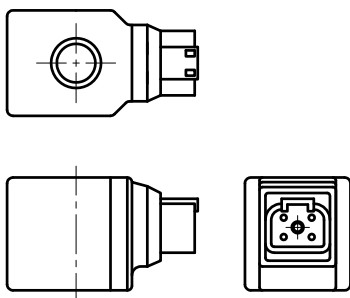

D13-05-24-26  
Connection=Deutsch connection  
德規電磁線圈

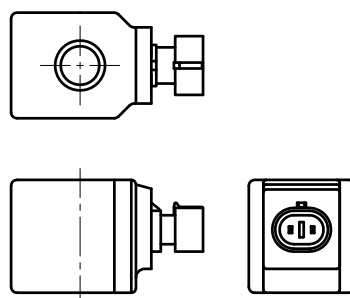

D13-06-24-26  
Connection=AMP super seal connection  
AMP超級密封電磁線圈

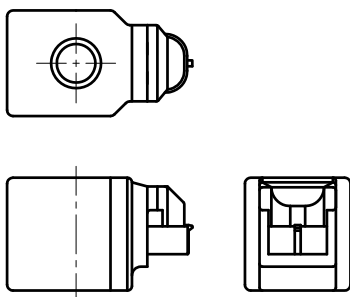

D13-07-24-26  
Connection=AMP super seal connection  
AMP超級密封電磁線圈

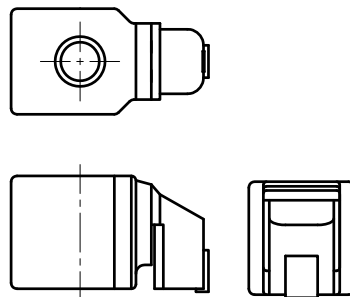

D13-08-24-26  
Connection=Deutsch connection  
德規電磁線圈

DIMENSIONS 尺寸

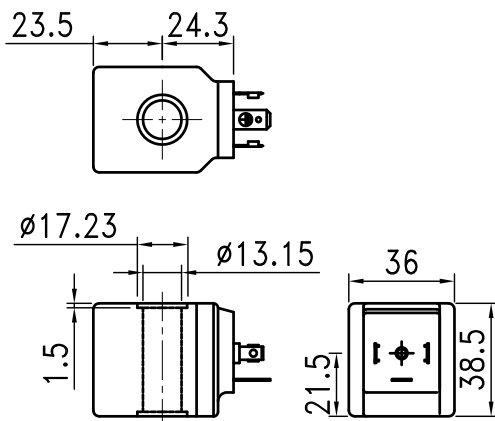



SYSTEM OF FLUID POWER

Coil Series 線圈

D14mm Coil series

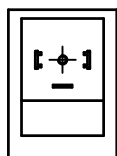
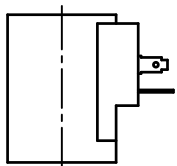
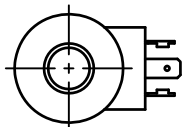

D14-01-12-26

Connection=A EN 175301-803 ISO 4400(DIN.43650)

電磁線圈

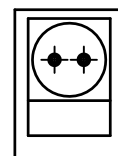
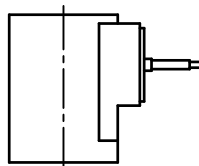
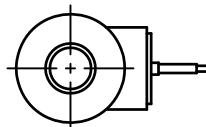

D14-02-12-26

Connection=Lead wires connection

出線型電磁線圈

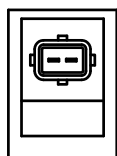
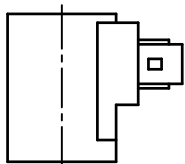
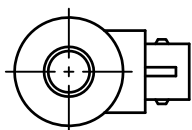

D14-03-12-26

Connection=AMP Junior connection

AMP初級電磁線圈

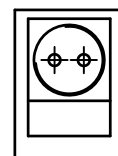
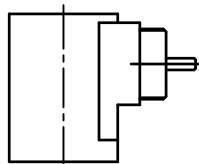
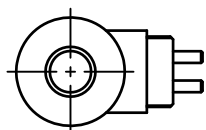

D14-04-12-26

Connection=M27x1 connection

M27x1 電磁線圈

DIMENSIONS 尺寸

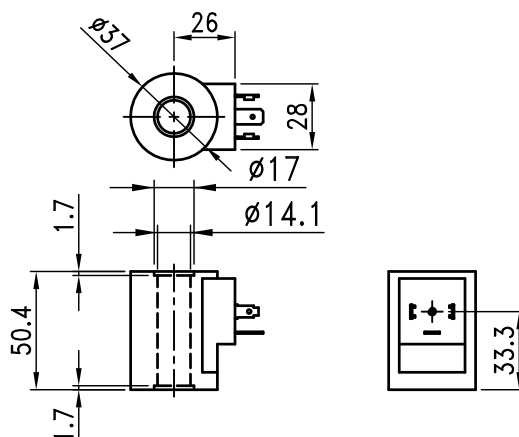



SYSTEM OF FLUID POWER

Coil Series 線圈

D16mm Coil series

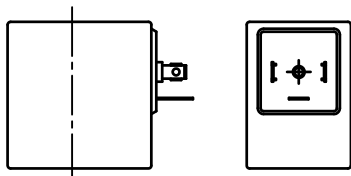
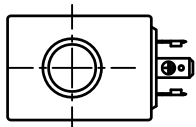

D16-01-12-28  
Connection=A EN 175301-803 ISO 4400(DIN.43650)  
電磁線圈

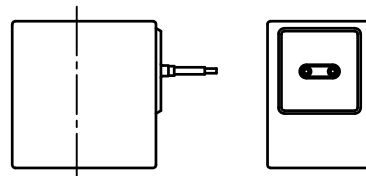
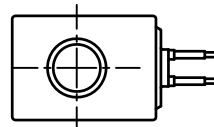

D16-02-12-28  
Connection=Lead wires connection  
出線型電磁線圈

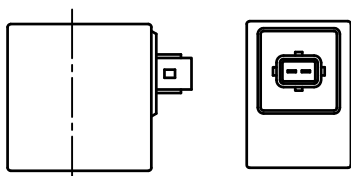
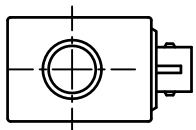

D16-03-12-28  
Connection=AMP Junior connection  
AMP初級電磁線圈

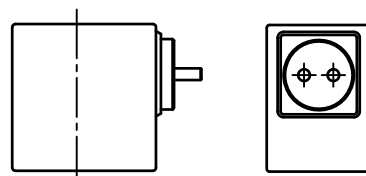
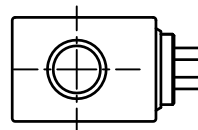

D16-04-12-28  
Connection=M27x1 connection  
M27x1 電磁線圈

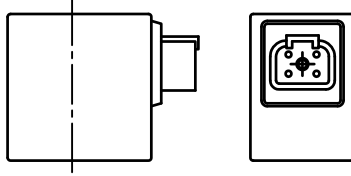
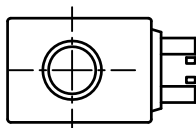

D16-05-12-28  
Connection=Deutsch connection  
德規電磁線圈

***DIMENSIONS 尺寸***

