



SYSTEM OF FLUID POWER

H B HYDRAULICS CO., LTD.

CHECK SHUTTLE VALVES 梭动阀

CST-02

HYDRAULIC DIAGRAM 油路符号

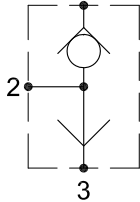

RATING DIAGRAM 流速表

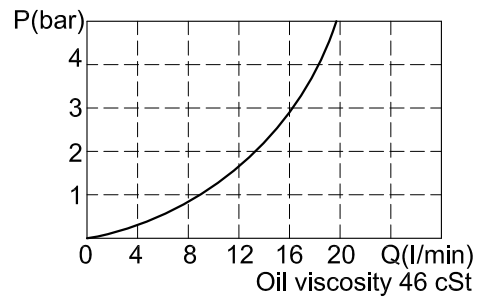

Qnom
(L/min)

Pmax
(Bar)

Pilot
ratio

20

400

--

DIMENSIONS (mm) 尺寸

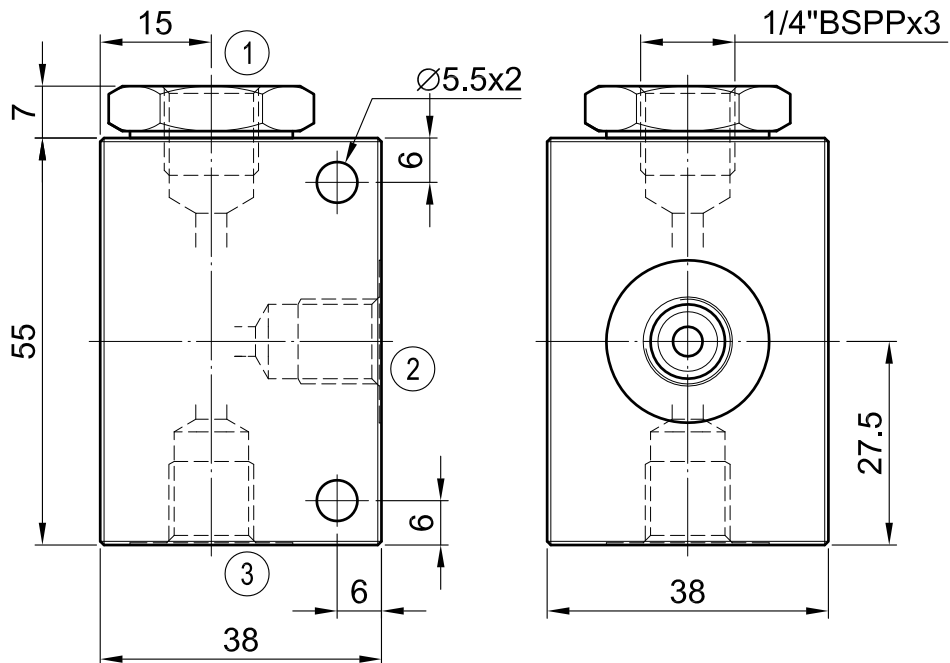

CST-02