



SYSTEM OF FLUID POWER

Coil Series 线圈

D13mm Coil series

D13 - 01 - 12 - 26

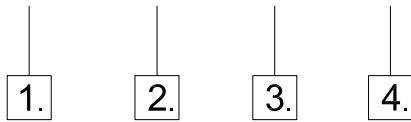

1. Coil Series 线圈
D13=13mm
D14=14mm
D16=16mm

3. Voltage 电压
12 = 12VDC
24 = 24VDC
110 = 110VAC
220 = 220VAC

2. Connection 连接器
01=A EN 175301-803 ISO 4400(DIN.43650)
02=Lead wires connection
03=AMP Junior connection
04=M27x1 connection
05=Deutsch connection
06=AMP super seal connection
07=AMP super seal connection
08=Deutsch connection

4. Absorbed power 功率
26 = DC Absorbed power 26 W
(For D13,D14)
28 = DC Absorbed power 28 W
(For D16)

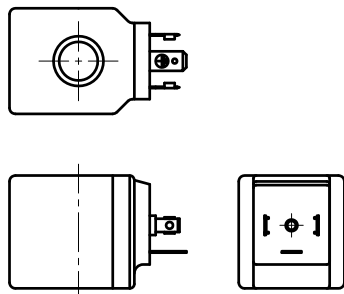

D13-01-12-26
Connection=A EN 175301-803 ISO 4400(DIN.43650)
电磁线圈

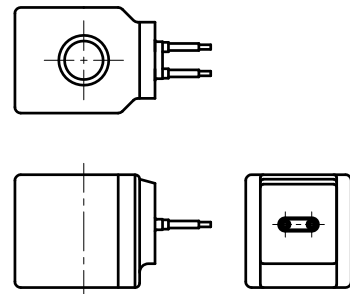

D13-02-24-26
Connection=Lead wires connection
出线型电磁线圈

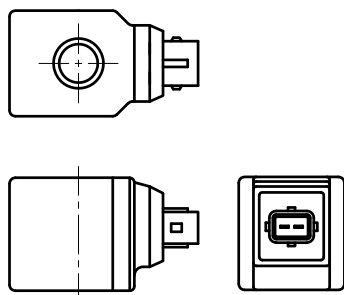

D13-03-24-26
Connection=AMP Junior connection
AMP初级电磁线圈

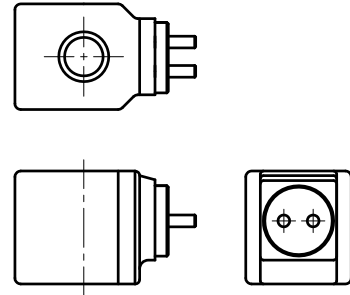

D13-04-24-26
Connection=M27x1 connection
M27x1电磁线圈



SYSTEM OF FLUID POWER

Coil Series 线圈

D13mm Coil series

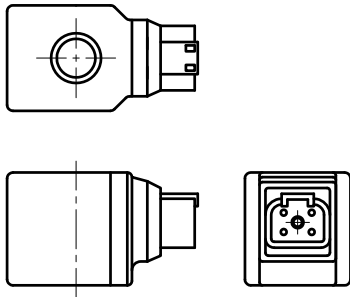

D13-05-24-26
Connection=Deutsch connection
德规电磁线圈

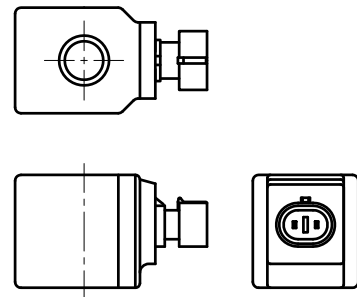

D13-06-24-26
Connection=AMP super seal connection
AMP超级密封电磁线圈

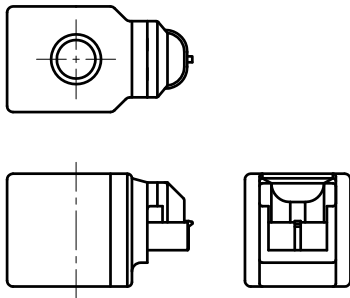

D13-07-24-26
Connection=AMP super seal connection
AMP超级密封电磁线圈

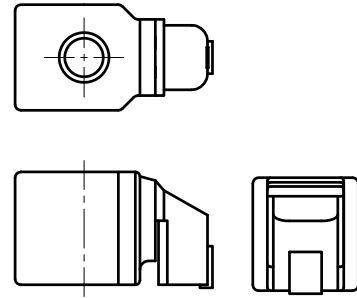

D13-08-24-26
Connection=Deutsch connection
德规电磁线圈

DIMENSIONS 尺寸

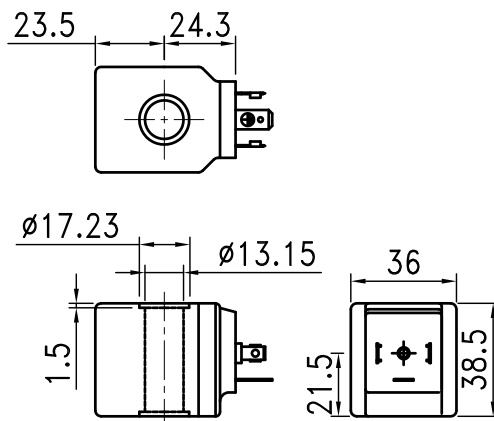



SYSTEM OF FLUID POWER

Coil Series 线圈

D14mm Coil series

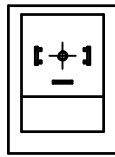
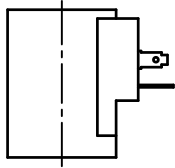
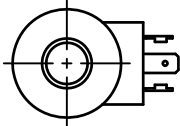

D14-01-12-26

Connection=A EN 175301-803 ISO 4400(DIN.43650)

电磁线圈

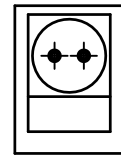
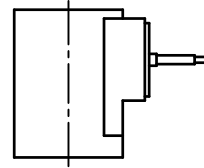
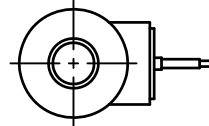

D14-02-12-26

Connection=Lead wires connection

出线型电磁线圈

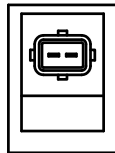
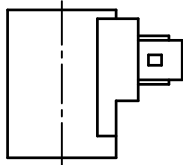
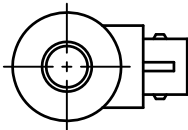

D14-03-12-26

Connection=AMP Junior connection

AMP初级电磁线圈

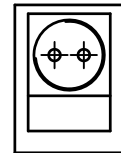
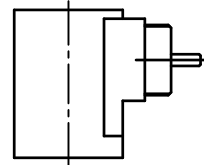
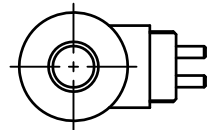

D14-04-12-26

Connection=M27x1 connection

M27x1电磁线圈

DIMENSIONS尺寸

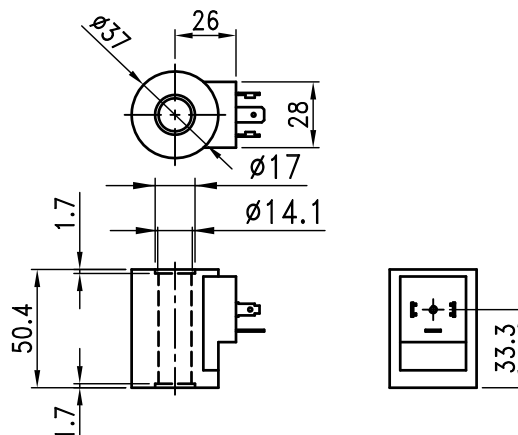



SYSTEM OF FLUID POWER

Coil Series 线圈

D16mm Coil series

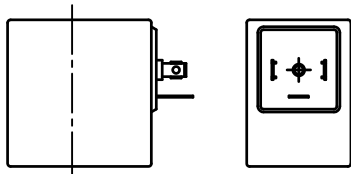
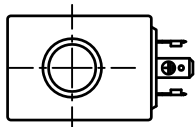

D16-01-12-28
Connection=A EN 175301-803 ISO 4400(DIN.43650)
电磁线圈

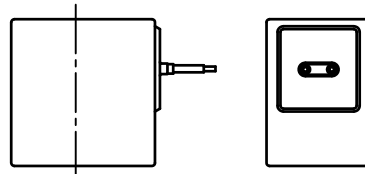
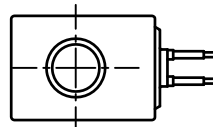

D16-02-12-28
Connection=Lead wires connection
出线型电磁线圈

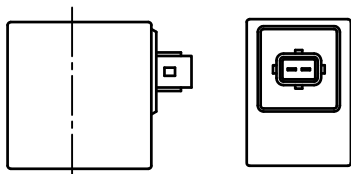
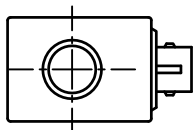

D16-03-12-28
Connection=AMP Junior connection
AMP初级电磁线圈

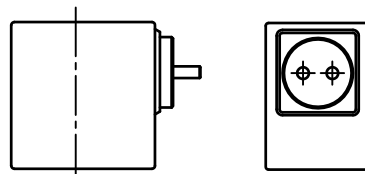
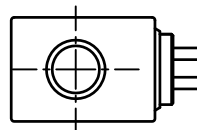

D16-04-12-28
Connection=M27x1 connection
M27x1电磁线圈

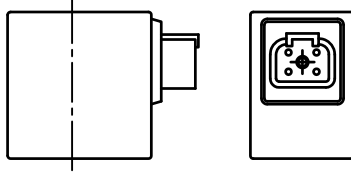
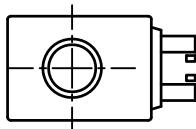

D16-05-12-28
Connection=Deutsch connection
德规电磁线圈

DIMENSIONS 尺寸

